

⑫ 実用新案公報 (Y2) 平1-40545

⑬ Int. Cl.⁴
A 63 F 9/22

識別記号 庁内整理番号
F-8403-2C

⑭ 公告 平成1年(1989)12月4日

(全3頁)

⑮ 考案の名称 感圧導電ゴムスイッチを備えたゲームコントロール装置

⑯ 実 願 昭60-172995

⑰ 公 開 昭62-82080

⑱ 出 願 昭60(1985)11月12日

⑲ 昭62(1987)5月26日

⑳ 考 案 者 河 島 庸 一 神奈川県平塚市南原1-28-1
㉑ 考 案 者 金 森 克 彦 神奈川県平塚市四之宮2432-2
㉒ 考 案 者 服 部 泰 神奈川県鎌倉市稲村ヶ崎5-36-5
㉓ 考 案 者 金 子 理 人 神奈川県平塚市南原1-28-1
㉔ 出 願 人 横浜ゴム株式会社 東京都港区新橋5丁目36番11号
㉕ 代 理 人 弁理士 小川 信一 外2名
㉖ 審 査 官 神 悦 彦
㉗ 参 考 文 献 実公 昭53-28325 (JP, Y2)

1

2

㉘ 実用新案登録請求の範囲

パーソナルコンピュータ用のゲームコントロール装置において、前記ゲームコントロール装置のスイッチに、押圧力によつて抵抗値が変化する感圧導電ゴムを使用し、この感圧導電ゴムスイッチに可変周波数型の発振回路を接続すると共に、この発振回路により制御される出力回路を設けたことを特徴とする感圧導電ゴムスイッチを備えたゲームコントロール装置。

考案の詳細な説明

〔産業上の利用分野〕

この考案は、押圧力によつて抵抗値が変化する感圧導電ゴムスイッチを備えたゲームコントロール装置に係わり、更に詳しくはパーソナルコンピュータやゲーム用コンピュータ等のゲームコントロールに係わる装置のスイッチを、その押圧力によつてコンピュータに送る信号の開閉周期を自在に制御出来るようにしたゲームコントロール装置に関するものである。

〔従来技術〕

従来、例えばコンピュータ用ゲームコントローラは、1個又は2個のON/OFFスイッチと、2組の可変抵抗器によつて構成され、可変抵抗器の出力はカーソルの移動等に用いられ、ON/OFFスイッチの信号はTVゲームのミサイル、ピ

ストルの発射等に用いられている。

このON/OFFスイッチは1回押すと1回ONするだけなので、機能が単純であり、ミサイルを連射したいときなどは、不都合であった。

〔考案の目的〕

この考案は、かかる従来の問題点に着目して案出されたもので、その目的とするところは、コンピュータ用ゲームコントローラのスイッチを感圧導電ゴムスイッチと可変周波数発振器を用いて出力回路を任意の周期で開閉できるようにすることで、ゲームの面白味を増すことができるようにした感圧導電ゴムスイッチを備えたゲームコントロール装置を提供するものである。

〔考案の構成〕

この考案は、上記目的を達成するためパーソナルコンピュータ用のゲームコントロール装置において、前記ゲームコントロール装置のスイッチに、押圧力によつて抵抗値が変化する感圧導電ゴムを使用し、この感圧導電ゴムスイッチに可変周波数型の発振回路を接続すると共に、この発振回路により制御される出力回路を設けたことを要旨とするものである。

〔考案の実施例〕

以下添付図面に基づき、この考案の実施例を説明する。

第1図はこの考案の回路図の一例を示し、1は抵抗、2はコンデンサー、3は押圧力によつて抵抗値が変化する感圧導電ゴム（例えば特公昭56-9187号公報、特公昭56-54019号公報）を用いたスイッチ、4はNAND回路等のICであつて、これらの各構成要素により可変周波数型の発振回路10を構成している。また、5はリレー駆動用トランジスタ、6は前記可変周波数型の発振回路10により制御されるリレー（出力回路）である。

そして、前記可変周波数型の発振回路10の発振周波数は、感圧導電ゴムスイッチ3の抵抗値とコンデンサー2の容量によつて決定される。

前記、発振回路10からの出力はトランジスタ5をスイッチさせ、リレー6が駆動される。

したがつて、感圧導電ゴムスイッチ3の抵抗を押しによつて変化させれば、前記発振回路10の発振周波数が変化し、リレーの開閉周期を任意に調節することができる。

次に、第2図はこの考案のブロック図でありAは発振回路、Bは信号出力を働かせる為のドライブ回路、Cはドライブ回路Bによつて動作されるリレー等の出力回路であり、ここよりの信号がコンピュータ等に送られる。

従つて、このリレー6の開閉をゲームコントローラーのスイッチとして使用すれば、コンピュータによる開閉信号の周期を使用者が任意に制御できるようになる。

第3図に、この考案の実施例を実際にゲームコ

ントローラーのスイッチとして使用している場合の構成図の一例を示し、ゲームコントローラー1の把持部12に、前記感圧導電ゴムスイッチ部3、発振回路10、リレー6を組み込み、コンピュータ13等に接続して、前述した操作を行うようにしたものである。

〔考案の効果〕

この考案は、上記のようにパーソナルコンピュータ用のゲームコントロール装置において、前記ゲームコントロール装置のスイッチに、押圧力によつて抵抗値が変化する感圧導電ゴムを使用し、この感圧導電ゴムスイッチに可変周波数型の発振回路を接続すると共に、この発振回路により制御される出力回路を設けたため、ゲームコントローラーのスイッチ信号の開閉周期の使用者の指先による押しで自由に制御できるので、コンピュータゲーム等を行なう上で新しい手法を使えるようになり、ゲームの面白味を増すことができる。又、新しいコントローラーが出現することで、新しいソフトウェアの開発も可能となる。

図面の簡単な説明

第1図はこの考案を実施した制御回路図、第2図はこの考案のブロック図、第3図はこの考案をゲームコントロール装置に把持部に実施した概略構成図である。

3……感圧導電ゴムスイッチ、6……リレー（出力回路）、10……発振回路、11……ゲームコントローラー。

第1図

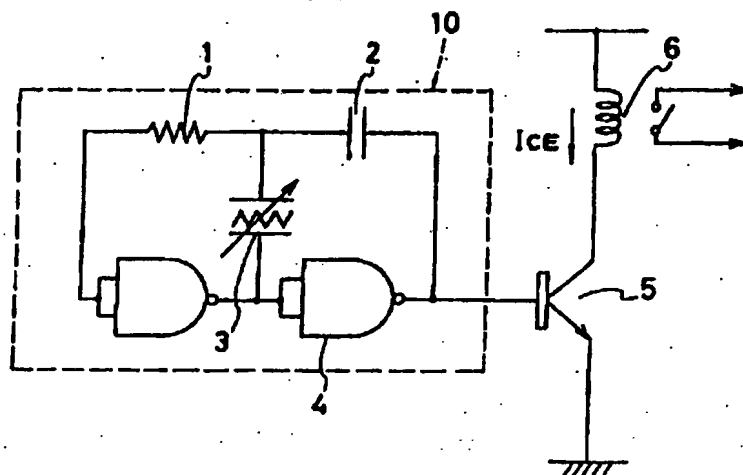

第2図

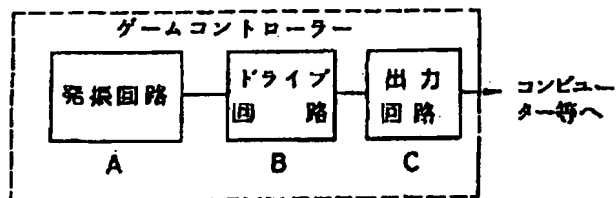

第3図

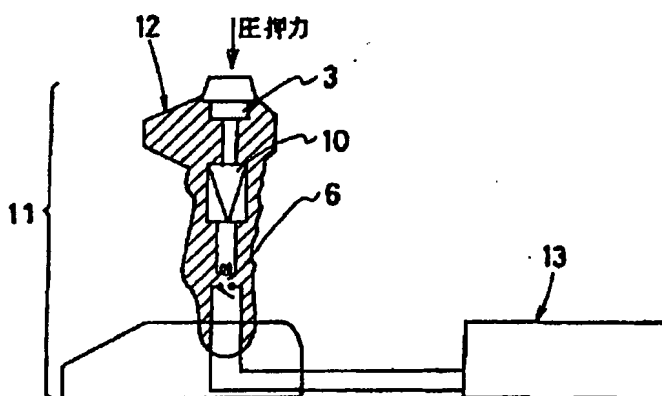

(19) Japanese Patent Office (JP)
(12) Examined Utility Model Publication (Y2)

(11) Publication of Utility Model
Application

H1-40545

(51) Int. Cl. ⁴	Identification Symbol	JPO File No.	(24)(44) Publication December 4, 1989
A 63 F 9/22		F-8403-2C	
(3 pages total)			
(54) Title of the Device	Game control device equipped with pressure sensitive conductive rubber switch		
	(21) Utility Model Application: S60-172995	(65) Publication S62-82090	
	(22) Filing Date: November 12, 1985	(43) S62 May 26, 1987	
(72) Inventor	Yasushi KAWASHIMA	1-28-1 Minamihara, Hiratsuka-shi, Kanagawa-ken	
(72) Inventor	Katsuhiko KANAMORI	2432-2 Shinomiya, Hiratsuka-shi, Kanagawa-ken	
(72) Inventor	Yasushi HATTORI	5-36-5 Inamuragasaki, Kamakura-shi, Kanagawa-ken	
(72) Inventor	Masahito KANEKO	1-28-1 Minamihara, Hiratsuka-shi, Kanagawa-ken	
(71) Applicant	Yokohama Rubber Co., Ltd.	5-36-11 Shinbashi, Minato-ku, Tokyo	
(74) Agent	Shinichi OGAWA, Patent Attorney	and 2 others	
Examiner	Nobuhiko KAMI		
(56) Reference Literature	Utility Model Publication S53-28325 (JP, Y2)		

[57] Scope of Registered Utility Model Claims

A game control device for a personal computer equipped with a pressure sensitive conductive rubber switch, wherein a pressure sensitive rubber is used whose resistance value changes with the pressing force on the switch of the above game control device and an output circuit is provided which, along with connecting a variable frequency oscillation circuit to this pressure sensitive conductive rubber, is controlled by this oscillation circuit.

Detailed Description of the Device

[Industrial Field of Application]

This device pertains to a game control device equipped with a pressure sensitive conductive rubber switch whose resistance value changes with pressing force, and more particularly, relates to game control device that enables a switch in a device for game control in personal computers or game computers to freely control the opening and closing cycle of signals sent to the computer by that pressing force.

[Prior Art]

In the past, for example, a computer game controller would consist of one or two On/Off switches and two groups of variable resistors, with the output of the variable resistors being used for cursor movements and the signals of the On/Off switch being used in the firing of missiles or pistols in a TV game.

The functions of this On/Off switch were simplistic because it would turn on only once if pressed once, and it was a drawback when someone wanted to launch a missile.

[Purpose of the Device]

Because it was conceived with a focus on such existing problems, an object of this device is to provide a game control device equipped with a pressure sensitive conductive rubber switch that is able to elevate the appeal of the game by designing a switch for a computer game controller so that it is capable of opening and closing an output circuit with a given frequency by utilizing a variable frequency oscillation circuit with pressure sensitive conductive rubber.

[Constitution of the Device]

This device, in a game control device used in a personal computer for achieving the aforementioned object, is one whose essential element consists of using pressure sensitive rubber whose resistance value changes with the pressing force on the switch of the above game control device and equipping it with an output circuit which, along with connecting a variable frequency oscillation circuit to this pressure sensitive conductive rubber, is controlled by this oscillation circuit.

[Embodiment of the Device]

We will explain an embodiment of this device on the basis of the attached drawings below.

3

Fig. 1 shows an example of the circuit diagram for this device, in which 1 is a resistor, 2 is a capacitor, 3 is a switch using pressure sensitive conductive rubber (as in, for example, Published Examined Application No. S56-9187 or Published Examined Application No. S56-54019) whose resistance changes with pressing force, 4 is an IC such as a NAND circuit, and variable frequency oscillation circuit 10 is constituted by each of these elements. In addition, 5 is a relay drive transistor and 6 is a relay (in the output circuit) controlled by the above variable frequency oscillation circuit 10 (output circuit).

The oscillation frequency of the above variable frequency oscillation circuit 10 is then determined by the resistance value of the pressure sensitive conductive rubber switch 3 and the capacity of capacitor 2.

As described above, the output from the above oscillation circuit 10 is switched by transistor 5, and relay 6 is driven.

Accordingly, if the resistance of the pressure sensitive conductive rubber switch 3 is changed by the pressing force, the oscillation frequency of oscillation circuit 10 changes and the opening and closing cycle of the relay can be adjusted at will.

Next, Fig. 2 is a block figure of this device in which A is an oscillation circuit, B is the drive circuit for controlling the signal output, and C is an output circuit such as a relay that is operated by the drive circuit B and signals from here are transmitted to the computer.

Thus, if the opening and closing of this relay 6 is used for the game controller switch, the user will be able to control the cycle of opening and closing signals via the computer at will.

In Fig. 3, we illustrate an example of a structural diagram

4

when the embodiment of this device is used as an actual game controller switch. Here, pressure sensitive conductive rubber switch 3, oscillation circuit 10, and a relay 6 are incorporated into the casing 12 of game controller 1 and are connected to computer 13 to perform the above operations.

[Effect of the Device]

Because this device utilizes a pressure sensitive conductive rubber whose resistance value changes with pressing force in a game control device for a personal computer and is provided with an output circuit which, along with connecting a variable frequency oscillation circuit to this pressure sensitive conductive rubber, is controlled by this oscillation circuit in the manner described above, the opening and closing cycle of the switch signal of a game controller can be freely controlled by pressing force from the finger of the user, so it will allow the use of new techniques in playing computer games and elevate the appeal of the games. Additionally, with the development of a new controller, the development of new software will also become possible.

Brief Explanation of Drawings

Fig. 1 is a control circuit diagram in which this device has been implemented, Fig. 2 is a block diagram of this device, and Fig. 3 is an outline configuration diagram in which this device is implemented in the casing on a game control device.

3.....pressure sensitive conductive rubber switch; 6.....relay (output circuit); 10.....oscillation circuit; 11.....game controller.

Fig. 1

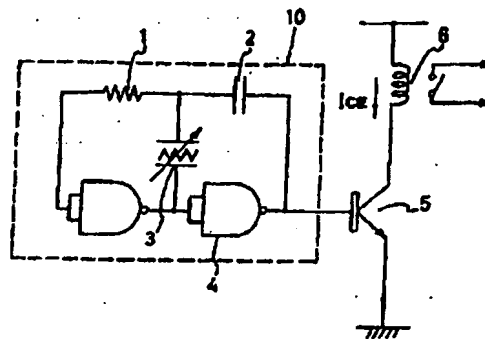
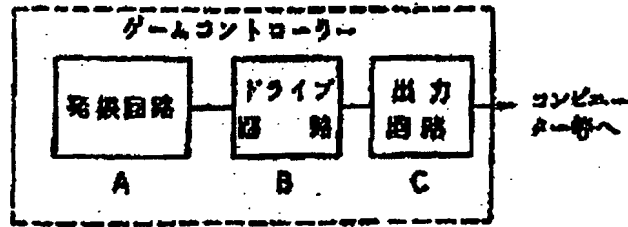

Fig. 2



[Callouts:]

[top middle] Game controller

A - Oscillation circuit

B - Drive circuit

C - Output circuit

[right] To computers

Fig. 3

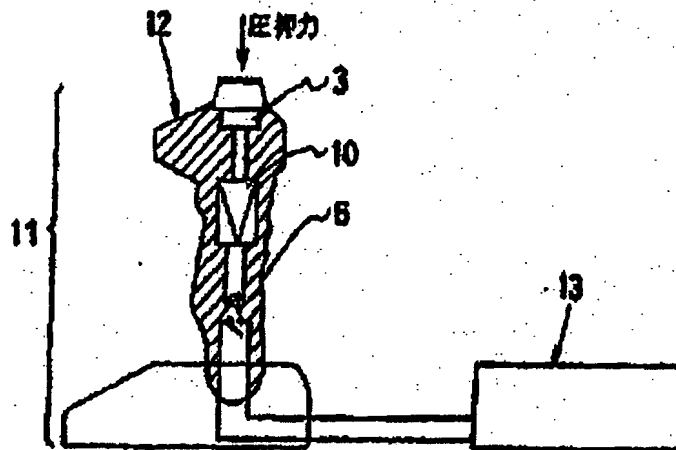

[Callouts:]

[top] Pressing force



los angeles

portland

miami

toronto

lima

london

santo domingo

Translation Certificate of Accuracy

57031
Klarquist Sparkman, LLP
JP 1-40545_English.doc: Japanese-English patent translation

The above referenced document has been translated accurately, completely and reliably, and reviewed for cultural appropriateness by two qualified translators—one to translate and one to edit. No additions or deletions have occurred that would change the context of the source language message; content has not been altered or misrepresented; specific industry terminology has been used throughout; the reading level (linguistic register) of the original document has been maintained; and if adaptation of the reading level has been requested, target text has been adapted following Client's instructions.

The translators translating the materials have professional translation experience, full fluency in the target language of the materials, the ability to read and understand the source language, knowledge and experience with the culture(s) of the intended audience, and adequate knowledge of the subject matter.

This Certificate of Accuracy is hereby issued within the limits set forth by NetworkOmni's Terms and Conditions. The signing representative acknowledges that the information related to the above referenced document is privileged and confidential communication, and that reproduction of said materials is strictly prohibited without written authorization.

Tashia Stone

Printed Name of Certifying Representative

Signature

Sr. Translation Project Manager

Title

November 27, 2006

Date

Exhibit 4 to the Request for Inter Partes Re-examination of

In re Patent No: 6,347,997

Issued: February 19, 2002

Applicant: Brad A. Armstrong

Title: Analog Controls Housed with Electronic Displays

Exhibit 5 to the Request for Inter Partes Re-examination of

In re Patent No: 6,347,997

Issued: February 19, 2002

Applicant: Brad A. Armstrong

Title: Analog Controls Housed with Electronic Displays

Exhibit 6 to the Request for Inter Partes Re-examination of

In re Patent No: 6,347,997

Issued: February 19, 2002

Applicant: Brad A. Armstrong

Title: Analog Controls Housed with Electronic Displays

(18)日本国特許庁 (J P)

(12) 公開実用新案公報 (U)

(11)実用新案出願公開番号

実開平5-87760

(43)公開日 平成5年(1993)11月28日

(51)Int.Cl ⁴	識別記号	庁内整理番号	F I	技術表示箇所
H 0 1 H 13/00	C	7250-5G		
13/52	E	4235-5G		

審査請求 未請求 請求項の数1(全2頁)

(21)出願番号 実願平4-26276

(22)出願日 平成4年(1992)4月22日

(71)出願人 000006220

ミツミ電機株式会社

東京都調布市田領町8丁目8番地2

(72)考案者 古川 尊

東京都多摩市乞田541 ハイネス・ビュ
ラ101

(72)考案者 平尾 雄博

東京都調布市田領町2丁目13番地19号 早
稲荘3号室

(74)代理人 弁理士 林 幸吉

(54)【考案の名称】 感圧スイッチ

(57)【要約】

【目的】 スイッチ操作時に於て、操作者の意思によつて、例えばビデオゲームのキャラクターの動作を自由にコントロールできるようにする。

【構成】 可動部30の下面に可動接点32が設けられているラバー接点29であつて、該可動接点32の下面に押し圧によつて抵抗値が変化する導電部33を装着する。

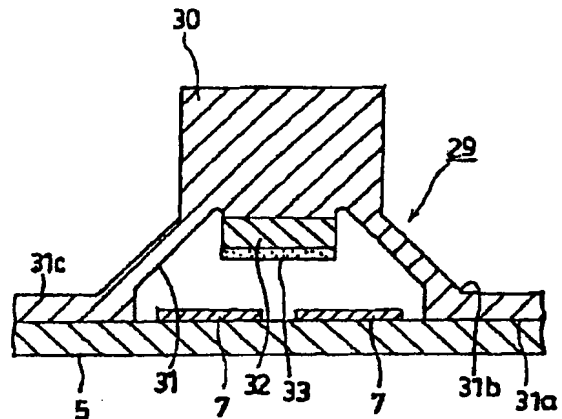

【実用新案登録請求の範囲】

【請求項1】 可動部の下面に可動接点が形成されたラバー接点に於て、該可動接点の下面に押し圧により抵抗値が変化する導電部を装着して成る感圧スイッチ。

【図面の簡単な説明】

【図1】 本考案を実施したビデオゲーム用のコントローラの平面図。

【図2】 本考案の要部の縦断正面図。

【図3】 従来型の縦断正面図。

【符号の説明】

- 5 基板
- 7 固定接点
- 29 ラバー接点
- 30 可動部
- 31 弾性脚部
- 82 可動接点
- 33 押し圧によって抵抗値が変化する導電部

【図1】

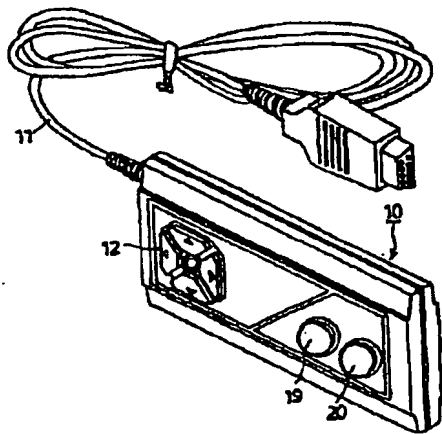

【図2】

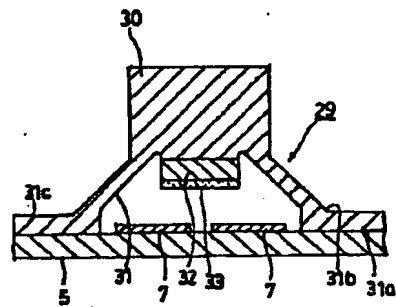

【図3】

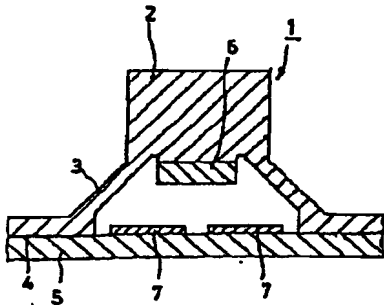

【考案の詳細な説明】

【0001】

【産業上の利用分野】

本考案は、感圧スイッチに関するものであり、特に、ラバー接点の可動部の押し圧力を変化させることによって電気的抵抗値を変化できるようにした感圧スイッチに関するものである。

【0002】

【従来の技術】

従来の此種ラバー接点を図3に従って説明する。図3は該ラバー接点の断面図である。図に於てラバー接点1の可動部2の外周から弾性脚部3が斜め下方へ斜設され、そして、該弾性脚部3の下端部から水平方向へ延設されて水平部4とし、該水平部4を基板5上に載置せしめる。又、該可動部2の下端部には導電性ゴム等にて可動接点6が夫々形成されており、且つ、該可動接点6の下端面は、可動部2を打鍵しないときには前記弾性脚部3の下端部より上方へ位置し、該可動部2の上面を下圧することにより、弾性脚部3の弾性的付勢に抗し、前記可動接点6が下降して基板5に配設されている配線パターンの固定接点7、7にオンすることになる。

【0003】

更に、該可動部2の前記打鍵を解除すれば、可動部2は弾性脚部3の弾性復元力により上動し、前記接点相互のオン状態が解除されることになる。

【0004】

【考案が解決しようとする課題】

上記従来型のラバー接点1は可動部2を打鍵すれば、該可動部2の下面に設けられている導電部である可動接点6が基板5に配設されている配線パターンの固定接点7、7にオンする。そして、該打鍵操作を解除することにより前記相互の電気的結合が解除される。従って、該ラバー接点1は単に電気的オン・オフの操作を為すだけであって、例えば、ビデオゲーム等のキャラクターの動作を操作者の意志で自由にコントロールすることはできない。

【0005】

そこで、スイッチ操作時に於て、操作者の意思により、例えばビデオゲームのキャラクターの動作を自由にコントロールできるようにするために解決せらるべき技術的課題が生じてくるのであり、本考案は該課題を解決することを目的とする。

【0006】

【課題を解決するための手段】

本考案は上記目的を達成するために提案せられたものであり、可動部の下面に可動接点が形成されたラバー接点に於て、該可動接点の下面に押し圧により抵抗値が変化する導電部を装着して成る感圧スイッチを提供するものである。

【0007】

【作用】

本考案は可動部の下面に形成されている導電部である可動接点の下面に更に押し圧によって電気的抵抗値が変化する導電部を装着しているもので、例えば、本考案のスイッチをビデオゲームのコントローラ用として用いているときには、操作者が本考案のスイッチの可動部を押圧する際、その押圧力の程度によって可動接点の下面に装着している前記導電部の電気的抵抗値が変化し、依って、該抵抗変化値がコントローラ信号の変化をうながす。斯くして、前記ビデオゲームのキャラクターの動作が操作者の意思により自由にコントロールされる。

【0008】

【実施例】

以下、本考案の一実施例を図1及び図2に従って詳述する。尚、説明の都合上、従来公知に属する構成も同時に説明し、対象部分は同一符号を用いるものとする。図1はコントローラ10を示し、ケーブル11を介してビデオゲーム機（図示せず）に接続される。コントローラ10の上面左の十字キー12は、画面上のキャラクターを上下左右に移動させるものである。右側の19、20はトリガーキーである。

【0009】

図2は前記コントローラ10に設けられている十字キー12のラバー接点29の縦断正面図である。尚、この実施例では十字キー12のラバー接点について説

明しているが之に限定せらるべきではない。該ラバー接点29は従来例にて説明したように弾性ゴム材より成り、前記十字キー12の夫々の中心部に可動部30が設けられ、各可動部30は夫々の外周中間部より弾性脚部31が斜め下方に斜設され、該弾性脚部31の下端部31aが基板5の上面に載置される。又、前記各可動部30の下端部には導電性ゴムにて夫々可動接点32が配設され、且つ、該可動接点32の下端部には、押し圧によって抵抗値が変化する導電部33が夫々印刷又は一体成形にて装着されている。そして該可動部30を押圧（打鍵操作）しない状態では、前記弾性脚部31の下端部31aより上方へ位置し、打鍵操作によって該可動部30は弾性脚部31の弾性付勢力に抗して下降し、基板5に設けた配線パターンの各固定接点7、7に電気的結合が為されるようになっている。そして、前記押圧動作を解除することにより、該可動部30が弾性脚部31の弾性復元力にて上動し、前記電気的結合が解除される。

【0010】

而して、該ラバー接点29の夫々の可動部30は夫々前記十字キー12の各先端部に設けた押圧部（各△印）の下部に対応して設けられており、該十字キー12の押圧部を指頭にて押圧することにより、該押圧部の方向にビデオゲームのキャラクターが移動し、而も、該指頭による押圧力の大小によって該キャラクターの移動速度が変化する。即ち、前記十字キー12の各押圧部に対する指頭による押圧力はラバー接点29の可動部30の下面に装着されている押し圧によって抵抗値が変化する導電部33によって電気抵抗が変化する。斯くして、ビデオゲームのキャラクターの動作が前記操作者の指頭による押圧力によって任意にコントロールすることができる。

【0011】

而して、上記一実施例はビデオゲームのコントローラ10に実施した場合を説明したが、その他、マルチバイブレーターの抵抗部に本考案のスイッチを用いることにより、周波数をスイッチの押し圧によって変化させることもできる。尚、この考案は、この考案の精神を逸脱しない限り種々の改変を為すことができ、そして、この考案が該改変されたものに及ぶことは当然である。

【0012】

【考案の効果】

この考案は、上記一実施例に詳述せる如く、スイッチの可動部を押圧してスイッチング動作を為すとき、該押圧力を変化させることによってスイッチの電気的抵抗値が変化し、依って、例えばビデオゲームのキャラクターの動作をスイッチの押圧力によって自由にコントロールすることができることになり、操作者の意思が直接に該キャラクターの動作に表現される。斯くして、該ビデオゲーム等に対する興味を一層助成する等、正に著大なる効果を奏する考案である。

(12) Japanese Unexamined Utility Model Application
Publication

(11) Publication No. 5-87760

(43) Publication Date: November 26, 1993

(21) Application No. 4-26276

(22) Application Date: April 22, 1992

(71) Applicant: Mitsumi Electric Co., Ltd. 8-8-2, Kokuryo-
cho, Chofu-shi, Tokyo

(72) Inventor: Hitoshi FURUKAWA

101 Highness Viewer, 541 Kotta, Tama-shi Tokyo

Inventor: Yoshihiro HIRAO

3 Somu-so, 2-13-19, Kokuryo-cho, Chofu-shi, Tokyo

(74) Agent: Patent Attorney, Yoshitaka HAYASHI

(54) [Title of the Invention] PRESSURE-SENSING SWITCH

(57) [Abstract]

[Object] To enable an operator to freely control, for example, the operation of a character of a video game, when performing a switching operation.

[Construction] In a rubber contact 29 in which a moving contact 32 is disposed on the bottom surface of a moving part 30, a conductive portion 33 whose resistance varies with a pressing force is attached to the bottom surface of the moving contact 32.

[Claim]

[Claim 1] A pressure-sensing switch comprising a rubber contact in which a moving contact is formed at a bottom surface of a moving part, wherein a conductive portion whose resistance changes with a pressing force is attached to a bottom surface of said moving contact.

[Brief Description of the Drawings]

[Fig. 1] Fig. 1 is a perspective view illustrating a controller for use in a video game, which embodies the present invention.

[Fig. 2] Fig. 2 is a longitudinal sectional front view illustrating the essential portion of the present invention.

[Fig. 3] Fig. 3 is a longitudinal sectional front view illustrating a conventional type.

[Reference Numerals]

- 5 substrate
- 7 fixed contact
- 29 rubber contact
- 30 moving part
- 31 elastic leg portion
- 32 moving contact
- 33 conductive portion whose resistance varies with a pressing force

[Detailed Description of the Invention]

[0001]

[Industrial Field of the Invention]

The present invention relates to a pressure-sensing switch and, more particularly, to a pressure-sensing switch in which electrical resistance is made variable by changing the pressure on a moving part of a rubber contact.

[0002]

[Description of the Related Art]

A conventional rubber contact of this type is discussed below with reference to Fig. 3. Fig. 3 is a sectional view illustrating the rubber contact. In Fig. 3, an elastic leg portion 3 obliquely slopes downward from the peripheral portion of a moving part 2 of a rubber contact 1, and a horizontal portion 4 which horizontally extends from the bottom of the elastic leg portion 3 is placed on a substrate 5. At the bottom of the moving part 2, a moving contact 6, such as conductive rubber, is formed. When the moving part 2 is not pressed, the bottom surface of the moving contact 6 is positioned above the bottom of the elastic leg portion 3. By pressing the top surface of the moving part 2 downward, the moving part 6 is lowered while being resisted by an elastic urging force of the elastic leg portion 3 so as to connect fixed contacts 7, 7 of a wiring pattern disposed on the substrate 5.

In order to achieve the above object, according to the present invention, there is provided a pressure-sensing switch comprising a rubber contact in which a moving contact is formed at a bottom surface of a moving part, wherein a conductive portion whose resistance changes with a pressing force is attached to a bottom surface of the moving contact.

[0007]

[Operation]

In the present invention, a conductive portion whose electrical resistance changes with a pressing force is fixed on the bottom surface of the moving contact, which is also a conductive portion, formed on the bottom surface of the moving part. Accordingly, when using the switch of the present invention as, for example, a controller of a video game, when the operator presses the moving part of the switch, the electrical resistance of the conductive portion fixed on the bottom surface of the moving contact changes according to the degree of the pressing force, thereby changing a signal from the controller. This enables the operator to freely control the operation of the character of the video game.

[0008]

[Embodiment]

An embodiment of the present invention is described in detail below with reference to Figs. 1 and 2. While

describing the present invention, the construction of the related art is simultaneously discussed, and counterpart components are designated with like reference numerals. Fig. 1 illustrates a controller 10, which is connected to a video game machine (not shown) via a cable 11. A cross key 12 positioned at the upper left portion of the controller 10 is used for vertically and horizontally moving characters on the screen. Reference numerals 19 and 20 shown at the right portion indicate trigger keys.

[0009]

Fig. 2 is a longitudinal sectional front view illustrating a rubber contact 29 of the cross key 12 provided for the controller 10. Although in this embodiment the rubber contact of the cross key 12 is discussed, the present invention is not restricted to this. As discussed in the description of the related art, the rubber contact 29 is formed of an elastic rubber material, and a moving part 30 is disposed at the central portion of each section of the cross key 12. An elastic leg portion 31 slopes obliquely downward from the peripheral middle portion of each moving part 30, and a bottom surface 31a of the elastic leg portion 31 is placed on the top surface of the substrate 5. A moving contact 32, which is formed of conductive rubber, is disposed at the bottom end of each moving part 30, and a conductive portion 33 whose resistance varies with pressure

is attached to the bottom end surface of the moving contact 32 by printing or integral molding. When the moving part 30 is not pressed (when the pressing operation is not performed), the conductive portion 33 is positioned above the bottom end surface 31a of the elastic leg portion 31. By performing the pressing operation, the moving part 30 is lowered while being resisted by an elastic urging force of the elastic leg portion 31 so that it is electrically connected to the fixed contacts 7, 7 of a wiring pattern disposed on the substrate 5. By discontinuing the pressing operation, the moving part 30 is lifted by an elastic restoring force of the elastic leg portion 31, thereby releasing the above-described electrical connection.

[0010]

The moving part 30 of the rubber contact 29 is provided at the bottom of the pressing portion (indicated by Δ) provided for each forward end of the cross key 12. By pressing the pressing portion of the cross key 12 with a fingertip, the character of the video game is moved in the direction corresponding to the pressed portion, and the speed of the character's movement changes according to the magnitude of the pressing force applied by a fingertip. That is, the pressing force applied by the fingertip on each pressing portion of the cross key 12 changes the electrical resistance through the conductive portion 33, whose

resistance changes according to the pressing force, fixed on the bottom surface of the moving part 30 of the rubber contact 29. Thus, the operation of the character of the video game can be freely controlled by the pressing force applied by the fingertip of the operator.

[0011]

In the foregoing embodiment, the present invention is used in the controller 10 of a video game. However, the switch of the present invention may be used for a resistor of a multi-vibrator so as to change the frequency by the pressing force on the switch. It should be noted that various modifications may be made to the present invention within the spirit of the invention, and the present invention encompasses such modifications.

[0012]

[Advantages]

As is seen from the detailed description of the above-described embodiment, the present invention offers the following enormous advantages. In performing the switching operation by pressing the moving part of the switch, the electrical resistance of the switch varies by changing the pressing force. This makes it possible to freely control, for example, the operation of a character of a video game, by the pressing force on the switch, and thus, the operator's intention can be directly reflected on the

[0003]

By stopping the releasing operation on the moving part 2, the moving part 2 is lifted by an elastic restoring force of the elastic leg portion 3 so as to disconnect the above-described contacts.

[0004]

[Problems to be Solved by the Invention]

According to the aforementioned conventional rubber contact 1, by pressing the moving part 2, the moving contact 6, which is a conductive portion, disposed on the bottom surface of the moving part 2 connects the fixed contacts 7, 7 of the wiring pattern disposed on the substrate 5. Then, by discontinuing the pressing operation, the above-described electrical connection is released. Thus, the rubber contact 1 merely effects an electrical on/off operation, and does not enable the operator to freely control, for example, the operation of a character in a video game.

[0005]

Accordingly, there is a technical problem to be solved, so that the operator is able to freely control, for example, the operation of a character in a video game by operating the switch. It is an object of the present invention to solve the above-described problem.

[0006]

[Means for Solving the Problems]

operation of the character. Hence, according to the present invention, the entertaining characteristics of, for example, the video game can be considerably increased.

(19) Japanese Patent Office (JP)

(12) **Unexamined Utility Model
Publication Bulletin (U)**

(11) Utility Model Application
Laid-Open Disclosure No.
Published Unexamined Application
H5-87760

(43) Laid-Open Disclosure Date
November 26, 1993

(51) Int. Cl. ⁵	Identification Symbols	JPO File Nos.	F1	Tech. Indic.
H 0 1 H 13/00 13/52	C E	7250-5G 4235-5G		

Request for examination: Not requested
Number of claims: 1 (Total of 2 pages)

(21) Application Number	H4-26276	(71) Applicant	000006220 Mitsumi Electric Co., Ltd. 8-8-2, Kokuryo-cho, Chofu-shi, Tokyo
(22) Filing Date	April 22, 1992	(72) Inventor	Hitoshi FURUKAWA 101 Highness Beulah, 541 Kotta, Tama-shi Tokyo
		(72) Inventor	Yoshihiro HIRAO 3 Somu-so, 2-13-19, Kokuryo-cho, Chofu- shi, Tokyo
		(74) Representative	Yoshitaka HAYASHI, Patent Attorney

(54) [Title of the Device] Pressure-sensitive switch

(57) [Abstract]

[Objective] To enable an operator to freely control, for example, the operation of a character of a video game, when performing a switching operation.

[Constitution] Comprises a rubber contact 29 on which a moving contact 32 is disposed on the undersurface of a moving part 30, wherein a conductive part 33 whose resistance is changed by pressing force is attached to the undersurface of said moving contact 32.

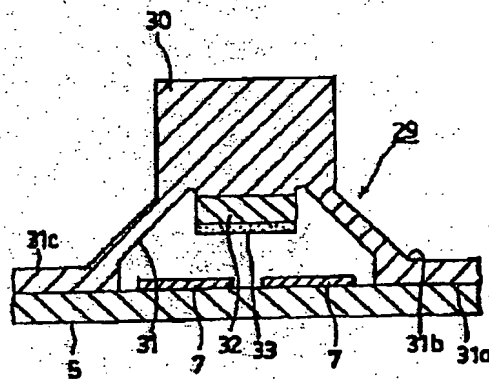

[Scope of Utility Model Registration Claims]

[Claim 1] A pressure sensitive switch comprising a rubber contact in which a moving contact is formed on the undersurface of a moving part, wherein a conductive part whose resistance changes with pressing force is attached to the undersurface of said moving contact.

[Brief Explanation of the Drawings]

[Fig. 1] Fig. 1 is a perspective view illustrating a controller for use in a video game, which embodies the present device.

[Fig. 2] Fig. 2 is a longitudinal sectional front view of an essential element of the present device.

[Fig. 3] Fig. 3 is a longitudinal sectional front view of a conventional type.

[Explanation of Symbols]

- 5 Substrate
- 7 Fixed contact
- 29 Rubber contact
- 30 Moving part
- 31 Elastic leg part
- 32 Moving contact
- 33 Conductive part whose resistance changes with pressing force

[Fig. 1]

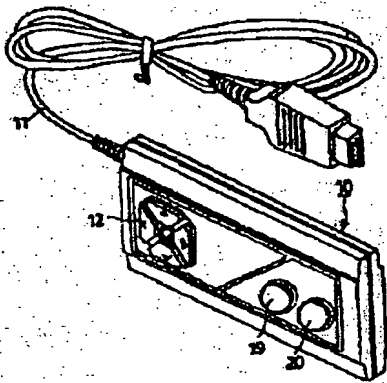

[Fig. 2]

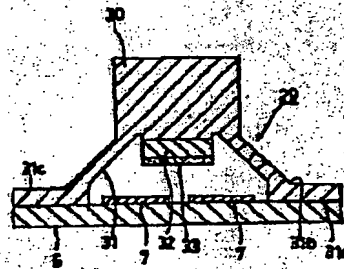

[Fig. 3]

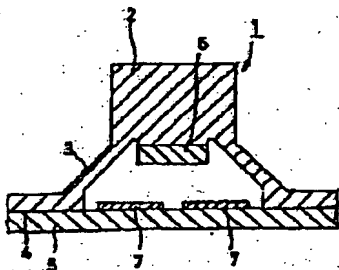

[Detailed Explanation of the Device]

[0001]

[Industrial Field of Application]

The present device relates to a pressure sensitive switch and, more particularly, to a pressure sensitive switch in which electrical resistance can be changed by altering the pressing force on the moving part of a rubber contact.

[0002]

[Prior Art]

A conventional rubber contact of this type is discussed below with reference to Fig. 3. Fig. 3 is a sectional view of the said rubber contact. In Fig. 3, an elastic leg part 3 slopes obliquely downward from the peripheral portion of a moving part 2 of a rubber contact 1, and a horizontal portion 4 that extends horizontally from the bottom of the elastic leg part 3 is placed on a substrate 5. At the bottom of moving part 2, a moving contact 6, such as conductive rubber, is formed. When moving part 2 is not depressed, the undersurface of moving contact 6 is positioned above the bottom of the above-described elastic leg part 3. By pressing the top surface of moving part 2 downward, moving part 6 is lowered while being resisted by the elastic bias of elastic leg part 3 so as to connect to the fixed contacts 7 and 7 of a wiring pattern disposed on substrate 5.

[0003]

In addition, by removing the above-described depression of the said moving part 2, moving part 2 is lifted by the elastic restoring force of elastic leg part 3 so as to disconnect the above-described contacts.

[0004]

[Problems the Device is to Solve]

When the above-described conventional rubber contact 1 presses on moving part 2, moving contact 6, which is a conductive part disposed on the undersurface of moving part 2, connects to the fixed contacts 7 and 7 of the wiring pattern disposed on substrate 5. Then, by discontinuing the said pressing operation, the above-described electrical connection is released. Thus, rubber contact 1 merely effects an electrical on/off operation, and does not enable the operator to freely control, for example, the operation of a character in a video game.

[0005]

Accordingly, there is a technical problem to be solved, so that the operator is able to freely control, for example, the operation of a character in a video game by operating the switch, and it is an objective of the present device to solve the above-described problem.

[0006]

[Means of Achieving the Objective]

The present device has been proposed in order to achieve the above objective, and provides a pressure sensitive switch comprising a rubber contact in which a moving contact is formed on the undersurface of a moving part, wherein a conductive part whose resistance changes with pressing force is attached to the undersurface of the moving contact.

[0007]

[Operation of the Device]

Inasmuch as the present device places a conductive part whose electrical resistance changes with pressing force onto the undersurface of a moving contact, which is also a conductive part that is formed on the undersurface of the moving part, when the switch of the present device is used, for example, as the controller of a video game, the electrical resistance of the conductive part affixed to the undersurface of the moving contact changes according to the degree of the pressing force when the operator presses the moving part of the switch, thereby changing the signal from the controller, and allowing the operator to freely control the operation of the character in the video game.

[0008]

[Embodiments]

An embodiment of the present device is described in detail below according to Figs. 1 and 2. While describing the present device, the construction of the related art is simultaneously discussed, and the subject components are designated with the same symbols. Fig. 1 illustrates a controller 10, which is connected to a video game machine (not shown) via a cable 11. A cross shaped key 12 positioned at the upper left part of controller 10 is used for vertically and horizontally moving characters on the screen. Numerals 19 and 20 shown at the right portion indicate trigger keys.

[0009]

Fig. 2 is a longitudinal sectional front view of rubber contact point 29 on the cross shaped key 12 provided for

controller 10. Although in this embodiment the rubber contact of cross shaped key 12 is discussed, it is not limited to this. As discussed in the description of the prior art, the said rubber contact point 29 is formed from an elastic rubber material, and a moving part 30 is disposed onto the center of each part of the cross shaped key 12. An elastic leg part 31 slopes obliquely downward from the peripheral center portion of each moving part 30, and undersurface 31a of the said elastic leg part 31 is placed on the top surface of substrate 5. Moving contact 32, which is formed of conductive rubber disposed on the bottom end of each of the above-described moving part 30, and conductive part 33, whose resistance varies with pressure, is attached by printing or integral molding to the bottom end surface of the moving contact 32. When pressing force is not applied to said moving part 30 (when the pressing operation is not performed), conductive part 33 is positioned above the bottom end surface 31a of the above-described elastic leg part 31. By performing the depressing operation, moving part 30 is lowered while being resisted by the elastic bias of elastic leg part 31 so that it is electrically connected to fixed contacts 7 and 7 on a wiring pattern disposed on substrate 5. By discontinuing the above-described pressing operation, said moving part 30 is lifted by the elastic restoring force of elastic leg part 31, thereby releasing the above-described electrical connection.

[0010]

Each moving part 30 of said rubber contact point 29 is provided at the bottom of the pressing part (indicated by Δ) provided for each forward end of the cross key 12. By depressing the respective pressing parts of cross shaped key 12 with a fingertip, the character of the video game is moved in the direction corresponding to the pressed part, and the speed of the character's movement changes according to the magnitude of the pressing force applied by a fingertip. More specifically, the pressing force applied by the fingertip on each pressing part of the cross shaped key 12 changes the electrical resistance through conductive part 33, whose resistance changes according to the pressing force, fixed on the undersurface of the moving part 30 of rubber contact point 29. Thus, the operation of the character in a video game can be freely controlled by the pressing force applied by the fingertip of the operator.

[0011]

Moreover, the foregoing embodiment described an instance in which present device is used in the controller 10 of a video game, but in addition to that, using the switch of the present device in the resistor of a multi-vibrator makes it possible to change the frequency with the pressing force of the switch. It should be noted that various modifications may be made to the present device within the spirit of the device, and it is natural that the present device encompasses such modifications.

[0012]

[Effects of the Device]

As we have described in detail in the above-described embodiment, this device offers the following enormous advantages. In performing the switching operation by pressing the moving part of the switch, the electrical resistance of the switch is varied by changing the pressing force. This makes it possible to freely control, for example, the operation of a character in a video game with the pressing force on the switch, and thus, the operator's intentions can be directly reflected in the operation of said character. Hence, according to the present device, the entertaining characteristics of the video game, for example, can be considerably increased.



los angeles

portland

miami

toronto

lima

london

santo domingo

Translation Certificate of Accuracy

56978
Klarquist Sparkman, LLP
JP 5-87760_English.doc: Japanese-English patent translation

The above referenced document has been translated accurately, completely and reliably, and reviewed for cultural appropriateness by two qualified translators—one to translate and one to edit. No additions or deletions have occurred that would change the context of the source language message; content has not been altered or misrepresented; specific industry terminology has been used throughout; the reading level (linguistic register) of the original document has been maintained; and if adaptation of the reading level has been requested, target text has been adapted following Client's instructions.

The translators translating the materials have professional translation experience, full fluency in the target language of the materials, the ability to read and understand the source language, knowledge and experience with the culture(s) of the intended audience, and adequate knowledge of the subject matter.

This Certificate of Accuracy is hereby issued within the limits set forth by NetworkOmni's Terms and Conditions. The signing representative acknowledges that the information related to the above referenced document is privileged and confidential communication, and that reproduction of said materials is strictly prohibited without written authorization.

Tashia Stone

Printed Name of Certifying Representative

Signature

Sr. Translation Project Manager

November 17, 2006

Title

Date

Exhibit 7 to the Request for Inter Partes Re-examination of

In re Patent No: 6,347,997

Issued: February 19, 2002

Applicant: Brad A. Armstrong

Title: Analog Controls Housed with Electronic Displays

(19) 日本国特許庁 (J P)

(12) 公開特許公報 (A)

(11) 特許出願公開番号

特開平5-326217

(43) 公開日 平成5年(1993)12月10日

(51) Int.Cl. ⁵	識別記号	庁内整理番号	F I	技術表示箇所
H 0 1 C 10/10	A			
G 0 1 L 1/18				
9/04	1 0 1	9009-2F		

審査請求 未請求 請求項の数1(全 3 頁)

(21) 出願番号	特願平4-121983	(71) 出願人	000006220 ミツミ電機株式会社 東京都調布市国領町8丁目8番地2
(22) 出願日	平成4年(1992)5月14日	(72) 発明者	古川 等 東京都多摩市乞田541 ハイネス・ビュ ラ101
		(72) 発明者	平尾 越博 東京都調布市国領町2丁目19番地13号 早 霧荘3号室
		(74) 代理人	弁理士 林 孝吉

(54) 【発明の名称】 感圧可変抵抗器

(57) 【要約】

【目的】 キーボードスイッチ等に容易に応用できる可変抵抗器を提供する。

【構成】 カーボンブラックやグラファイト等の炭素粉末をシリコンゴム材に混合し、一体成形して感圧可変抵抗器1を成形する。この感圧可変抵抗器1を、例えばスイッチ5に応用する場合は、キートップ6の下面に導電層7を介して感圧可変抵抗器1を設ける。キートップ6を押下げると、感圧可変抵抗器1が固定接点9、10に当接する。押圧力によって炭素粉末間の接触圧が高まり、固定接点9、10と導電層7を導通させる異方性導電作用が表われる。押圧力に対応して感圧可変抵抗器1の抵抗値が変化し、固定接点9、10間の電圧を任意に手動操作できる。

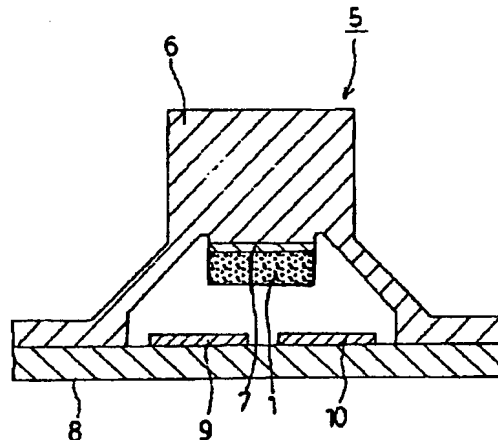

【特許請求の範囲】

【請求項1】 導電物質を弾性ゴム材に混合して一体成形し、異方導電性を付与した感圧可変抵抗器。

【発明の詳細な説明】

【0001】

【産業上の利用分野】 この発明は可変抵抗器に関するものであり、特にソリッド構造の可変抵抗器に関するものである。

【0002】

【従来の技術】 従来、抵抗体と摺動接点とにより構成された可変抵抗器が、回路電圧の調整用に使用されている。また、応力に対して電気抵抗が変化する半導体感圧素子の特性を利用したストレインゲージ等のセンサは広く知られている。

【0003】

【発明が解決しようとする課題】 例えば、コンピュータのカーソル移動キーやスクロールキー、自動車のパワーウィンドウスイッチ等は単にオンとオフを切替えるスイッチである。之等のキー或いはスイッチに、操作者の意志に応じてアナログ的に操作量を調整することが可能な機能を付加すれば、所謂マンマシンインタフェースとしての性能向上が期待できる。

【0004】 このアナログ的操作を実現するためには、ハードウェアやソフトウェアを変更しなければならないことは当然ながら、キー或いはスイッチに電気量操作手段として可変抵抗器を使用することが必要となる。しかし、従来の可変抵抗器を之等のキーやスイッチに応用することは、体積、重量、耐久性やコスト等において問題がある。例えば、従来の機械式の可変抵抗器をキーボードのキーに用いることは、スペース的にも耐久性や操作性についても問題が生ずる。

【0005】 そこで、この発明は簡単な構成で高耐久性を有し、操作感覚に見合った抵抗変化を得ることができ、且つ低コストの可変抵抗器を提供してエレクトロニクス機器の機能の向上に寄与することを目的とする。

【0006】

【課題を解決するための手段】 この発明は上記目的を達成するために、炭素粉末等の導電物質を弾性ゴム材に混合して一体成形し、異方導電性を付与した感圧可変抵抗器を提案するものである。

【0007】

【作用】 弾性ゴム材の中へ混入された炭素粉末等の導電物質は、通常の状態では導電物質間の接触圧が低く、電気的に高抵抗となっている。この弾性ゴム材の両面に圧力を加えると、弾性ゴム材が応力によって変形し、応力方向の導電物質間の接触圧が高くなり、抵抗値が減少して応力の方向に導電可能な異方性の導電作用が表われる。抵抗値は応力に対してほぼ比例的に変化するので、荷重応力の変化を抵抗値の変化として捉えることが容易に行える。

【0008】

【実施例】 以下、この発明の一実施例を図に従って詳述する。図1は、シリコンゴム等の弾性ゴム材にカーボンブラックやグラファイト等の炭素粉末を混合して適宜な厚さのゴム板として成形した感圧可変抵抗器1である。図2に示すように、感圧可変抵抗器1の両面に電極2の電極3、4を接続し、感圧可変抵抗器1の両面に応力を作用させると、応力方向の炭素粉末間の接触状態が変化し、矢印で示す異方性の導電作用が表われる。

【0009】 図3は、応力 F と抵抗値 R との関係を示し、無応力状態では高抵抗であり、圧力が大きくなるに従って炭素粉末の応力方向の接触状態が密になり低抵抗へと変化する。従って、電極3、4間の電圧を測定することにより、応力を電気量に変換して表わすことができ、荷重計等に利用することができる。尚、感圧可変抵抗器1の体積や断面の縦横比、硬度、炭素系粉末の混合比によって種々の抵抗値範囲及び負荷電力の抵抗器を提供できる。

【0010】 図4は感圧可変抵抗器1をスイッチ5に応用した例を示し、ラバーキートップ6の可動接点に感圧可変抵抗器1を使用している。感圧可変抵抗器1とラバーキートップ6との間には導電層7が設けられている。導電層7は感圧可変抵抗器1の一面に印刷若しくは一体成形等の手段によって形成する。ラバーキートップ6を押下げると、図5に示すように回路基板8上に配設された二つの固定接点9、10に感圧可変抵抗器1が接触し、感圧可変抵抗器1の異方性導電路 a 、 b と、その上部の導電層7を介して二つの固定接点9、10間に回路が形成されるが、接触圧が低い状態では、感圧可変抵抗器1の抵抗値が高く、ラバーキートップ6を更に押圧して接触圧を高くするに伴って抵抗値が低下する。

【0011】 例えば、このスイッチ5を発振回路の構成素子として使用すれば、押圧力によって発振周波数を任意に制御することができる。従って、コンピュータのキーボードのスクロールキーやカーソル移動キー等にこのスイッチ5を使用し、抵抗値によってスクロール速度やカーソル移動速度が変化するようにハードウェア及びソフトウェアを対応させておけば、操作者の意志に応じてスクロール速度、カーソル移動速度、コンピュータゲームにおけるキャラクターの反応速度等を自在に制御することができる。

【0012】 尚、この発明は上記一実施例に限定するものではなく、この発明の精神を逸脱しない限り種々の改良を為すことができ、この発明がそれらの改良されたものに及ぶことは当然である。

【0013】

【発明の効果】 この発明の感圧可変抵抗器は、上記一実施例に於て詳述したように、押圧力によって抵抗値を可変できるソリッド抵抗器であるので、断線等の故障発生が殆どなく、生産性にすぐれており、低コストで大量生

産できる。そして、摺動子をもたないソリッド形なのでキーボードやコントローラ等への適用が容易であり、可変抵抗器の応用範囲が拡大されて、種々のエレクトロニクス機器の機能向上に寄与できる。

【図面の簡単な説明】

【図1】 本発明の感圧可変抵抗器の正面図。

【図2】 感圧可変抵抗器の作用を示す解説図。

【図3】 応力と本発明の感圧可変抵抗器の抵抗値との関係を表わす解説グラフ。

【図4】 感圧可変抵抗器を使用したスイッチの断面図。

【図5】 図4のスイッチのオン状態における電流経路を

示す解説図。

【符号の説明】

- 1 感圧可変抵抗器
- 2 電源
- 3, 4 電極
- 5 スイッチ
- 6 ラバーキートップ
- 7 導電層
- 8 回路基板
- 9, 10 固定接点

【図1】

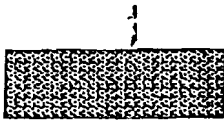

【図2】

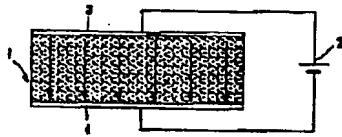

【図3】

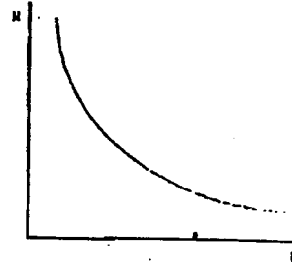

【図4】

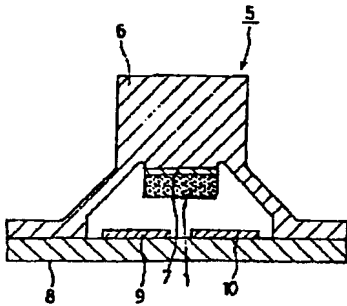

【図5】

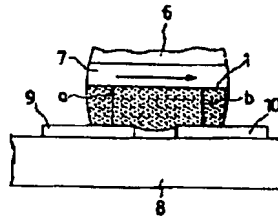

(19) Japan Patent Office (JP) (12) Laid Open Patent Publication (A) (11) Laid Open Patent Application Publication No.
 Laid Open Patent Application H05-326217
 (43) Publication date December 10, 1993

(51) Int. Cl ⁶	ID	Office Cont. No.	F1	Technical description
H01C 10/10 G01L 1/18 9/04	A 101	9009-2F		
<u>Examination Apply No Number of claims 1 (total 3 pages)</u>				
(21) Appl. No. Patent Application H04-121993 (22) Filing date May 14, 1992	(71) Applicant 000006220 Mitsumi Electric., Ltd. 8-8-2 Kokuryo-cho, Chofu-shi, Tokyo (72) Inventor Hitoshi Furukawa Hainesu Byura 101 541 Kotta, Tama-shi, Tokyo (72) Inventor Yoshihiro Hirao Hayagiri-so 3 2-19-13 Kokuryo-cho, Chofu-shi, Tokyo (74) Representative Koukishi Hayashi, Patent Attorney			

(54) [Title of the invention] Pressure-sensitive variable resistor

(57) [Abstract]

[Objective] To provide a variable resistor that can easily be applied to keyboards and the like.

[Construction] A pressure-sensitive variable resistor 1 is formed by mixing carbon powder such as carbon black and graphite with a silicon rubber material and integrally molding it. For applying it, for example, to a switch 5, a pressure-sensitive variable resistor 1 is provided on the bottom surface of a key top 6 via an electro-conductive layer 7. When the key top 6 is pressed down, the pressure-sensitive variable resistor 1 abuts secure contact points 9 and 10. The contact pressure between carbon powder particles is increased by the applied pressure and anisotropic conductivity is established between the secure contact points 9 and 10 and the electro-conductive layer 7. The resistance of the pressure-sensitive variable resistor 1 is changed according to the applied pressure so that the voltage between the secure contact points 9 and 10 can be manually and arbitrarily controlled.

[Claim]

[Claim 1] A pressure-sensitive variable resistor formed by mixing an electro-conductive material with an elastic rubber material and integrally molding it for anisotropic conductivity.

[Detailed explanation of the invention]

[0001]

[Scope of the invention]

The present invention relates to a variable resistor, and in particular to a variable resistor having a solid structure.

[0002]

[Prior art technology]

Traditionally, variable resistors comprising a resistor and sliding contact points are used for circuit voltage adjustment. On the other hand, sensors such as straight gauges using the properties of semiconductor pressure-sensitive elements having stress related variable electric resistance are well known.

[0003]

[Problems overcome by the invention]

For example, cursor motion keys and scroll keys in computers and power window switches in automobiles are switches that simply switch between ON and OFF. If these keys and switches are provided with a function to adjust the analogue operation rate according to the intention of the operator, improvement in terms of so-called man-machine performance is anticipated.

[0004]

In order to realize this analogue operation, a variable resistor as an electric rate operating means should be installed in keys or switches while, needless to say, hardware and software must be modified. However, there are problems with volume, weight, durability, and cost in applying the prior art variable resistors to these keys and switches. For

example, when prior art mechanical variable resistors are used in the keys of a keyboard, problems occur with space, durability, and operability.

[0005]

Therefore, the purpose of the present invention is to provide a variable resistor having a simple structure and high durability, yielding changes in resistance corresponding to operational feeling, and requiring low cost for improved functions of electronic devices.

[0006]

[Problem resolution means]

In order to achieve the above purpose, the present invention proposes a pressure-sensitive variable resistor formed by mixing an electro-conductive material such as carbon powder with an elastic rubber material and integrally molding it for anisotropic conductivity.

[0007]

[Efficacy]

An electro-conductive substance such as carbon powder mixed in the elastic rubber material normally exhibits low contact pressure between the electro-conductive substances, yielding high electric resistance. When the elastic rubber is pressured on both sides, the elastic rubber is deformed by the stress and has increased contact pressure between the electro-conductive substances in the stress direction, decreasing the resistance and establishing anisotropic conductivity in the stress direction. The resistance is changed in proportion to the stress. The change in load stress is easily translated to the change in resistance.

[0008]

[Embodiment]

An embodiment of the present invention is described in detail hereafter with reference to the drawings. Fig.1 shows a pressure-sensitive variable resistor 1 formed by mixing an elastic rubber material such as silicon rubber with carbon powder such as carbon black and graphite and molding it into a rubber plate having appropriate thickness. As shown in Fig.2, electrodes 3 and 4 of a power source 2 are connected to the pressure-sensitive variable resistor 1 on either side. Then, stress is applied to either side of the pressure-sensitive variable resistor 1. Consequently, the contact mode of the carbon powder in the stress direction is changed and anisotropic conductivity in the arrowed direction is established.

[0009]

Fig.3 shows the relationship between stress F and resistance R . The resistance is high in the absence of stress. As the pressure is increased, the carbon powder becomes a denser contact mode in the stress direction, resulting in decreased resistance. Therefore, measurements of the voltage between the electrodes 3 and 4 provide the stress expressed in electrical quantity, which can be used, for example, in load meters. Resistors having different ranges of resistance and load power can be provided depending on the volume, cross-sectional aspect ratio, hardness, and carbon powder mixing rate of the pressure-sensitive variable resistor 1.

[0010]

Fig. 4 shows an embodiment in which the pressure-sensitive variable resistor 1 is applied to a switch 5. Here, the pressure-sensitive variable resistor 1 is used as the movable contact point of a rubber key top 6. An electro-conductive layer 7 is provided between the pressure-sensitive variable resistor 1 and the rubber key top 6. The electro-conductive layer 7 is formed on one surface of the pressure-sensitive variable resistor 1 by printing or integral molding. When the rubber key top 6 is pressed down, the pressure-sensitive variable resistor 1 makes contact with two secure contact points 9 and 10 on a circuit board 8 as shown in Fig.5, establishing a circuit between the two secure contact points 9 and 10 via anisotropic electro-conductive paths a and b of the pressure-sensitive variable resistor 1 and the electro-conductive layer 7 above it. When the contact pressure is low,

the pressure-sensitive variable resistor 1 has high resistance. The resistance is reduced as the rubber key top 6 is further pressed down and the contact pressure is increased..

[0011]

For example, when the switch 5 is used as a component in an oscillation circuit, the oscillation frequency can be controlled depending on the pressing force. When the switch 5 is used in the scroll keys and cursor motion keys of a computer keyboard and the hardware and software is modified to change the scroll rate and cursor moving speed according to the resistance, the scroll rate, cursor moving speed, and character reaction speed in computer games can be fully controlled according the intention of the user.

[0012]

The present invention is not restricted to the above embodiment and various modifications can be made without departing from the scope of the invention. Needless to say, the present invention contains all such modifications.

[0013]

[Efficacy of the invention]

The pressure-sensitive variable resistor of the present invention is, as described in detail with regard to the above embodiment, a solid resistor that has a variable resistance according to the pressing force, which is subject to very little failures such as breaking, is excellent in productivity, and suitable for mass-production with low cost. It is a solid-type without a sliding element. Therefore, the pressure-sensitive variable resistor of the present invention can be easily applied to keyboards and controllers and contributes to extended use of variable resistors and, subsequently, improved functions of various electronic devices.

[Brief explanation of the drawings]

[Fig.1] A plane view of the pressure-sensitive variable resistor of the present invention.

[Fig.2] An illustration to explain the behavior of the pressure-sensitive variable resistor.

[Fig.3] A graphical representation showing the relationship between stress and resistance of the pressure-sensitive variable resistor of the present invention.

[Fig.4] A cross-sectional view of a switch using the pressure-sensitive variable resistor.

[Fig.5] An illustration showing the electric path within the switch in Fig.4 when it is on.

[Legend]

- 1 pressure-sensitive variable resistor
- 2 power source
- 3,4 electrode
- 5 switch
- 6 rubber key top
- 7 electro-conductive layer
- 8 circuit board
- 9, 10 secure contact point

CERTIFICATE OF TRANSLATION

I Roger P. Lewis, whose address is 42 Bird Street North, Martinsburg WV 25401, declare and state the following:

I am well acquainted with the English and Japanese languages and have in the past translated numerous English/Japanese documents of legal and/or technical content.

I hereby certify that the Japanese translation of the attached translation of documents identified as:

Laid Open Patent Application H05-326217;
"Pressure-sensitive variable resistor"

is to the best of my knowledge and ability true and accurate.

I further declare that all statements contained herein of our own knowledge, are true, that all statements of information and belief are believed to be true.

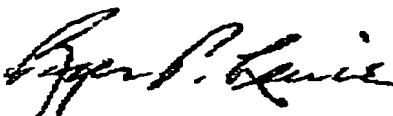

ROGER P. LEWIS

September 26, 2006

Exhibit 8 to the Request for Inter Partes Re-examination of

In re Patent No: 6,347,997

Issued: February 19, 2002

Applicant: Brad A. Armstrong

Title: Analog Controls Housed with Electronic Displays

Exhibit 9 to the Request for Inter Partes Re-examination of

In re Patent No: 6,347,997

Issued: February 19, 2002

Applicant: Brad A. Armstrong

Title: Analog Controls Housed with Electronic Displays

Exhibit 10 to the Request for Inter Partes Re-examination of

In re Patent No: 6,347,997

Issued: February 19, 2002

Applicant: Brad A. Armstrong

Title: Analog Controls Housed with Electronic Displays

Exhibit 11 to the Request for Inter Partes Re-examination of

In re Patent No: 6,347,997

Issued: February 19, 2002

Applicant: Brad A. Armstrong

Title: Analog Controls Housed with Electronic Displays



(12) **EUROPEAN PATENT APPLICATION**
 published in accordance with Art. 158(3) EPC

(43) Date of publication:
 15.04.1998 Bulletin 1998/16

(51) Int. Cl.⁶: A63F 9/22

(21) Application number: 97904597.8

(86) International application number:
 PCT/JP97/00483

(22) Date of filing: 21.02.1997

(87) International publication number:
 WO 97/32641 (12.09.1997 Gazette 1997/39)

(84) Designated Contracting States:
 DE ES FR GB IT

- TOSAKI, Kenji
 Sega Enterprises, Ltd.
 Tokyo 144 (JP)
- DATE, Toshinori
 Sega Enterprises, Ltd.
 Tokyo 144 (JP)

(30) Priority: 05.03.1996 JP 47691/96
 26.03.1996 JP 70769/96
 24.04.1996 JP 102413/96

(71) Applicant:
 SEGA ENTERPRISES, LTD.
 Tokyo 144 (JP)

(74) Representative: SERJEANTS
 25, The Crescent
 King Street
 Leicester, LE1 6RX (GB)

(72) Inventors:
 • HIMOTO, Atsunori
 Sega Enterprises, Ltd.
 Tokyo 144 (JP)

(54) **CONTROLLER AND EXTENSION UNIT FOR CONTROLLER**

(57) An expansion unit (50, 60 or 70) is connected to a controller body (10) including an analog direction key (12), a digital direction key (14), command buttons (20a-20z), command levers (22l, 22r) etc. An expansion unit (50) including a photo emitting unit (52) is connected to thereby make the controller cordless. An expansion unit (60) includes a photo detecting unit (65), whereby shooting games in which an enemy on a monitor screen can be shot can be played. An expansion unit (70) including a vibration unit (75) is connected, whereby a vibration is given to the controller body (10) to make a shooting game more realistic. New functions can be added to the conventional controller, and the new functions can be added freely without making any change to the controller body.

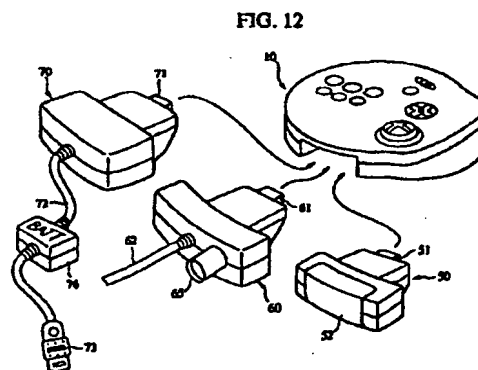

Description

TECHNICAL FIELD

The present invention relates to a controller which outputs various instructions to an electronic device, such as a game device, by operation of an operator.

BACKGROUND ART

More than several years have passed since video game devices for domestic use first appeared, and recently a large variety of entertaining games have been developed. Video games for the domestic use are very popular as an entertainment. Domestic game devices are connected to input means called controllers. Players operate the controllers to output various instructions to the game devices.

Thus the controllers intervene between the players and the game devices, and act as a man-machine interface, and thus are very important to the game devices. The ease of operation as well as the functional ability of the controllers are closely related to the feasibility and entertainment value of games.

Various types of controllers for the domestic game devices have been proposed, but in general most controllers for the domestic video game devices include direction keys which command directions as well as a plurality of command buttons.

However, the command buttons of the conventional controller can make only one command by one operation thereof, and are unsuitable to continuously make commands. It is very difficult especially to make commands which are continuously changed. When continuously changed commands must be made, nothing suffices other than unnatural operations of pushing the command buttons for various periods of time or pushing the command buttons repeatedly a number of times.

The direction buttons of the conventional controller can command only four or eight directions, and cannot command directions between these directions, and continuous direction changes.

The conventional controller originally had only the direction keys and two command buttons, but as games have become complicated, two command buttons have been increased to three, and recently six command buttons have become common. Six buttons are a limit to be easily operated by one player, which has made it difficult to meet new games which require more command buttons.

Recently the method for operating the controller has become increasingly complicated, which makes it difficult for players to stably operate the controller. A controller which can be stably operated is required.

When a game producer thinks up contents of a game, it is necessary for him to keep in mind the ease of operational of the controller. Also, the functional ability of a controller and game contents are closely related.

Usually common controllers are used when games are designed. Thus, their functional ability and ease of operation of the controller limit the contents of a game.

Conversely, in order to give priority to the game's contents, new controllers that are more suitable for the game contents are provided in some cases. Unfortunately, a large burden is thereby placed on the users.

To add controller functions to suit the contents of a particular game, expansion units can be connected to a controller. In order for any expansion unit to be connected, a controller which permits any expansion unit which will appear to be connected must be designed. This method also has a limit.

Conventional controllers, on the other hand, are totally inconsiderate of a player's grip. For example, the contour of a conventional controller is merely rectangular or parallel, and sometimes a handle is merely provided on the controller.

Players may be children or adults, and may have various hand sizes and various gripping habits. Depending on the game contents, it may be better to change the way of carrying the controller. The conventional controller does not meet such requirements.

An object of the present invention is to provide a controller expansion unit which can freely realize a controller having a function suitable for contents of a game.

Another object of the present invention is to provide a controller which can be gripped in various ways according to the operator's preference.

Further another object of the present invention is to provide a controller which can be gripped in ways such that operators can easily operate the controller.

Further another object of the present invention is to provide a controller which can make commands which are continuously changed.

Further another object of the present invention is to provide a controller which can command an arbitrary direction and continuously changed directions.

Further another object of the present invention is to provide a controller which can include a number of command buttons.

Further another object of the present invention is to provide a controller which can be stably operated.

DISCLOSURE OF THE INVENTION

The above-described objects are achieved by a controller expansion unit which is to be inserted between a controller body including an operation key and a game apparatus, and which supplies a command signal generated by the operation key of the controller body to the game apparatus body, whereby new functions can be added to the conventional controller, and the new functions can be added freely without making any change to the controller body.

The above-described controller expansion unit may comprise function expansion means for expanding a function of the controller body, and conversion means

for converting the command signal from the controller body, based on a function expanded by the function expansion means, and supplying the converted command signal to the game apparatus body.

In the above-described controller expansion unit, the function expansion means may include photo signal outputting means for outputting the signal to the game apparatus body as a photo signal, and the photo signal outputted by the photo signal outputting means may be detected by photo signal detecting means of the game apparatus body, whereby the controller can be cordless.

In the above-described controller expansion unit, the function expansion means may include photo signal detecting means for detecting a photo signal from the outside, and the conversion means may add the photo signal from the photo signal detecting means to the command signal from the controller body, whereby gun games are possible, in which an optical signal from the video monitor is detected to shoot an enemy on a monitor screen.

In the above-described controller expansion unit, the function expansion means may include vibration means for giving a vibration to the controller body, based on the signal from the game apparatus body or the controller body, whereby in a shooting game, for example, vibrations generated upon shooting are added to thereby make the game realistic.

In the above-described controller expansion unit, the function expansion means may include an operation key for effecting a specific operation, and the conversion means may add an operation signal generated by the specific operation key to the command signal from the controller body, whereby new operation keys can be easily added.

In the above-described controller expansion unit, the function expansion means may include memory means for storing information, and the memory means may store information supplied from the game apparatus body or the controller body, or information supplied to the game apparatus body or the controller body, whereby new memories are added to thereby reinforce functions of the game apparatus.

In the above-described controller expansion unit, the function expansion means may include display means for displaying information, and the display means may display information from the game apparatus body or the controller body, whereby new image display means is added to thereby reinforce functions of the game apparatus.

In the above-described controller expansion unit, the function expansion means may include clock means for counting time, and time display means for displaying time, and the conversion means may add time information counted by the clock means to the command signal from the controller body, whereby games making use of time information can be played.

In the above-described controller expansion unit, the function expansion means include rotation angle

detecting means for detecting a rotation angle of the controller body supported thereon, and the conversion means may add rotation angle signals detected by the rotation angle detecting means to the command signal from the controller body, whereby the controller body can be operated as a steering wheel of a car or others.

In the above-described controller expansion unit, the function expansion means may include inclination detecting means for detecting an inclination of the controller body, and the conversion means may add an inclination signal detected by the inclination detecting means to the command signal supplied from the controller body, whereby an inclination of the controller body can be an operation signal, which make games realistic.

In the above-described controller expansion unit, the conversion means supplies an inclination signal given by the inclination detecting means in place of a direction command signal from the controller body, whereby a direction command can be made by an inclination of the controller, which realizes games having new operational feelings.

The above-described objects are achieved by a controller comprising a controller body including an operation key, and the above-described controller expansion unit.

The above-described objects are achieved by a controller comprising, on an operation surface of a body of the controller, a direction key for a direction command, and a plurality of command buttons for outputting a single command, the operation surface of the controller body having a substantially circular outer edge so that an operator can grip the controller body at any positions around the outer edge of the operation surface.

In the above-described controller, a part of the outer edge of the operation surface of the controller body may be shaped in relation to a specific direction of the direction key so that, when the operator holds the operation surface with his hand, he can know the specific direction of the direction key, whereby when an operator grips the operational surface with a hand, a specific direction of the direction key can be known.

In the above-described controller, the controller body may include lugs to be held by the operator, and a part of a lug may be shaped in relation to a specific direction of the direction key so that, when the operator grips the operation surface with his hand, he can know the specific direction of the direction key, whereby an operator can know a specific direction of the direction key.

The above-described objects are achieved by a controller comprising: a controller body; a direction key disposed on a first operational surface of the controller body, and commanding a direction; a plurality of command buttons disposed on the first operational surface and outputting one command by one operation; and a command lever disposed on a second operational surface of the controller and outputting continuously

changed command amounts by one operation, whereby continuously changed commands can be easily made.

In the above-described controller it is preferable that the direction key comprises: a direction key operating unit; discrete direction determining means for determining a specific direction out of a plurality of prescribed directions, based on a state of the direction key operation unit; and continuous direction determining means for determining continuous command directions, based on a state of the direction key operation unit, whereby an arbitrary direction command and continuously changed direction commands can be made.

In the above-described controller it is preferable that the direction key further includes change-over means for interchanging the discrete direction determining means and the continuous direction determining means.

In the above-described controller it is preferable that the command lever is a command button which outputs one command by one operation.

In the above-described controller it is preferable that the direction key and the command buttons are disposed at positions which facilitate operation with the left and the right thumbs of an operator when he holds the controller with the left and the right hands, and the command lever is disposed at a position which facilitates operation with the fingers other than the thumbs, whereby a number of buttons and keys can be easily operated.

In the above-described controller it is preferable that the controller body includes two grips to be held by an operator; and the direction key and the command buttons are disposed at positions which facilitate operation with the left and the right thumbs of the operator when he holds the two grips with the left and the right hands, and the command lever is disposed at a position which facilitates operation with the fingers other than the thumbs. When the controller is operated, held with the hands, the grips are firmly held with both hands, which makes the operation stable.

In the above-described controller it is preferable that a projection is provided on the second operational surface of the controller body; the controller can be placed on a flat surface, supported by the projection and the two grips; the direction key and the command buttons are disposed at positions which facilitate operation with the left and the right thumbs of an operator when the controller is placed on a flat surface, and the command lever is disposed at a position which facilitates operation with the fingers other than the thumbs. When the controller is placed on a desk or the like to be operated, the controller is set on a flat surface such as a desk or the like, supported by the projection and the two grips, which makes the operation stable.

BRIEF DESCRIPTION OF THE DRAWINGS

FIG. 1 is a plan view of the controller according to a

first embodiment of the present invention.

FIG. 2 is a right side view of the controller according to the first embodiment.

FIG. 3 is a perspective view of the back side of the controller according to the first embodiment as slantly viewed.

FIG. 4 is a perspective view of the controller according to the first embodiment in a state in which the controller is held by an operator.

FIG. 5 is a rear side view of the controller according to the first embodiment of the present invention with an expansion unit detached from the controller body.

FIG. 6 comprises detailed views of an expansion connector of the controller body of the controller, and a connector of an expansion unit.

FIG. 7 is a block diagram of the controller according to the first embodiment with an expansion unit which does not add expansion functions connected.

FIG. 8 is a block diagram of the controller according to the first embodiment with an expansion unit which adds expansion functions connected.

FIG. 9 comprises views of pin arrangements of the connectors of an expansion unit and the controller body of the controller according to the first embodiment of the present invention.

FIG. 10 comprises explanatory views of conversion of command signals from the controller body which is conducted by the expansion unit according to the first embodiment of the present invention.

FIG. 11 is a block diagram of the conventional controller with an expansion unit connected.

FIG. 12 is a perspective view of an example of the expansion unit for the controller according to the first embodiment of the present invention.

FIG. 13 is a block diagram of an example of the expansion unit for the controller according to the first embodiment of the present invention, which uses infrared ray signals.

FIG. 14 is a block diagram of an example of the expansion unit for the controller according to the first embodiment of the present invention, which includes a photo detector.

FIG. 15 is a block diagram of an example of the expansion unit for the controller according to the first embodiment of the present invention, which includes a vibration unit.

FIG. 16 is a perspective view of an example of the expansion unit for the controller according to the first embodiment of the present invention, which includes a joy stick.

FIG. 17 is a block diagram of an example of the expansion unit of the controller according to the first embodiment of the present invention, including the joy stick.

FIG. 18 is a plan view of another example of the expansion unit including a joy stick for the controller according to the first embodiment of the present invention.

FIG. 19 is a perspective view of said other example of the expansion unit including the joy stick for the controller according to the first embodiment of the present invention.

FIG. 20 is a perspective view of an example of the expansion unit including a track ball for the controller according to the first embodiment of the present invention.

FIG. 21 is a block diagram of the example of the expansion unit including the track ball for the controller according to the first embodiment.

FIG. 22 is a plan view of another example of the expansion unit including the track ball for the controller according to the first embodiment of the present invention.

FIG. 23 is a perspective view of said another example of the expansion unit including the track ball for the controller according to the first embodiment of the present invention.

FIG. 24 is a perspective view of said another example of the expansion unit which adds a memory module to the controller according to the first embodiment of the present invention.

FIG. 25 is a block diagram of the example of the expansion unit which adds a memory module to the controller according to the first embodiment of the present invention.

FIG. 26 is a perspective view of an example of the expansion unit including an image display for the controller according to the first embodiment of the present invention.

FIG. 27 is a block diagram of the example of the expansion unit including the image display unit for the controller according to the first embodiment of the present invention.

FIG. 28 is a plan view of an example of the expansion unit including a time display unit for the controller according to the first embodiment of the present invention.

FIG. 29 is a block diagram of the example of the expansion unit including the time display unit for the controller according to the first embodiment of the present invention.

FIG. 30 is a perspective view of an example of the expansion unit including a handle shaft for the controller according to the first embodiment of the present invention.

FIG. 31 is a block diagram of the example of the expansion unit including the handle shaft for the controller according to the first embodiment of the present invention.

FIG. 32 is a perspective view of the held state of the example of the expansion unit including hand shaft for the controller according to the first embodiment of the present invention.

FIG. 33 is a perspective view of an example of the expansion unit including an inclination detecting unit for the controller according to the first embodiment of the

present invention.

FIG. 34 is a block diagram of the example of the expansion unit including the inclination detecting unit for the controller according to the first embodiment of the present invention.

FIG. 35 is a plan view of the controller according to a second embodiment of the present invention.

FIG. 36 is a front view of the controller according to the second embodiment of the present invention.

FIG. 37 is a right side view of the controller according to the second embodiment of the present invention.

FIG. 38 is a perspective view of an example of the expansion unit including an inclination detection unit with a vibration function of the controller according to the second embodiment.

FIG. 39 is a back side view of the controller according to the second embodiment of the present invention with the expansion unit removed from the controller body.

FIG. 40 is an exploded perspective view of the example of the expansion unit including an inclination detection unit with the vibration function of the controller according to the second embodiment.

FIG. 41 is a block diagram of the example of the expansion unit including an inclination detection unit with the vibration function of the controller according to the second embodiment.

FIG. 42 comprises explanatory views of an operation of the example of the expansion unit including an inclination detection unit with the vibration function of the controller according to the second embodiment.

FIG. 43 is a plan view of the controller according to a third embodiment of the present invention.

FIG. 44 is a perspective view of the controller according to the third embodiment of the present invention as viewed slantly from the back.

FIG. 45 is a right side view of the controller according to the third embodiment of the present invention.

FIG. 46 is a bottom view of the controller according to the third embodiment of the present invention.

FIG. 47 is an explanatory view of a mechanism of the direction key of the controller according to the third embodiment of the present invention.

FIG. 48 comprises explanatory views of a mechanism of the command lever of the controller according to the third embodiment of the present invention.

FIG. 49 is a perspective view of the controller according to the third embodiment of the present invention, which shows an operational state.

FIG. 50 is a block diagram of a circuit of the controller according to the third embodiment of the present invention, which shows a structure thereof.

BEST MODE FOR CARRYING OUT THE PRESENT INVENTION

First Embodiment

The controller according to a first embodiment of the present invention will be explained with reference to FIGs. 1 to 34. FIG. 1 is a plan view of the controller according to the present embodiment. FIG. 2 is a right side view of the controller according to the present embodiment. FIG. 3 is a perspective rear side view of the controller according to the present embodiment as slantly viewed. FIG. 4 is a perspective view of the controller according to the present embodiment, which shows a way in which an operator holds the controller. FIG. 5 is a perspective rear side view of the controller according to the present embodiment in a state where the expansion unit is detached from the controller body. FIG. 6 comprises views of pin arrangements of a connector of the expansion unit and of an expansion socket of the controller body.

Structure of the Controller

The controller according to the present embodiment comprises a controller body 10 and an expansion unit 30.

The controller body 10 provides basic functions of the controller. As shown in FIG. 1, a start button 16 and a change-over switch 18 are disposed at a central lower part of an operation side 10a on the front side of the controller body 19, an analog direction key 12 and a digital direction key 14 are disposed on the left side of the operation face 10a, and six command buttons 20x, 20y, 20z, 20a, 20b, 20c are disposed on the right side of the operation face 10a. A command lever 22l is disposed on the central left side of an operation side 10c on the back side of the controller body 10, and a command lever 22r is disposed on the central right side of the operation side 10d. A screw hole 29 is formed in the center of the back side of the controller body 10.

As described above, the controller according to the present embodiment has the analog direction key 12, the digital direction key 14, the start button 16, the change-over switch 18 and the command buttons 20x, 20y, 20z, 20a, 20b, 20c on the operation side 10a on the front side, and the command levers 22l, 22r respectively on operation sides 10c, 10d on the back side.

The start button 16 is of the type that one command can be inputted with one push. The start button 16, which is disposed at the central lower part of the operation side 10a, is difficult to press frequently, and is mainly used to give commands that are not used during a game, such as the start command.

The change-over switch 18 is provided for ensuring compatibility with conventional controllers. When the change-over switch 18 is slid to the left, the compatible mode which is the same as the conventional controllers

is available. In this mode, the analog direction key 12 is invalid while the digital direction key 14, the start button 16, the command buttons 20x, 20y, 20z, 20a, 20b, 20c and the command levers 22l, 22r are valid. Games which are played by the use of the conventional controllers can be played by the use of the innovative controller according to the present embodiment. When the change-over switch 18 is slid to the right, the analog direction key 12 is valid, and games which are played by the use of the innovative controller according to the present embodiment can be played.

The present embodiment includes two direction keys 12, 14. The analog direction key 12 commands all continuous directions over 360°, thus making the so-called analog direction commands. The digital direction key 14 commands 8 separate preset directions, thus making the so-called digital direction commands. Both direction keys 12, 14, which are disposed on the left side of the front operation side 10a, are usually operated with the left hand of a player.

The analog direction key 12 has an operation plate (not shown) which is free to tilt by operations of a player. Based on the tilt direction of the operation plate, a command direction is detected.

The digital direction key 14 has an operation plate (not shown) which is free to tilt by operations of a player. When the operation plate is tilted, switches (not shown) disposed on the upper, lower, left and right sides of the plate are pressed to detect 8 directions including the upper and lower directions, the left and right directions and the intermediate directions therebetween.

The command buttons 20x, 20y, 20z, 20a, 20b, 20c are of the type that one command is inputted by one push of one of the buttons. The buttons 20x, 20y, 20z, 20a, 20b, 20c, which are disposed on the right side of the operation side 10a on the front side, are usually operated with the thumb of the right hand of an operator.

The command levers 22l, 22r are pulled toward the operator to input continuously changing command signals. The command levers 22l, 22r, which are disposed on the operation sides 10c, 10d on the left and right sides of the back side, are operated by pulling them toward the operator with the fingers of both hands except the thumbs, e.g., with the index fingers and the middle fingers when the operator holds the controller with both hands.

The command levers 22l, 22r respectively include operation levers (not shown). The command levers 22l, 22r are operated to thereby swing the operation levers, and can output continuously changing command signals corresponding to swing angles of the operation levers.

As shown in FIG. 3, the expansion unit 30 is mounted on the center of the back side of the controller body 10. The command levers 22l, 22r are disposed on the operation sides 10c, 10d on the left and the right sides of the expansion unit 30.

As shown in FIG. 1, the controller body 10 has a

substantially circular shape which is defined by an outer edge about 13 cm in diameter of the operation side 10a. This suitably sized circular edge allows a player to comfortably grip the controller at any position around the outer edge of the operation side 10a. To enable an operator to comfortably operate the controller, it is preferred that the circular shape of the operation side 10a of the controller body 10 has a diameter of about 9 - 17 cm.

The outer edge of the operation side 10a of the controller body 10 defines the substantially circular shape but defines a larger-radius arc on the left side 10b of the analog direction key 12. In the present embodiment, the arc has a diameter of about twice the diameter of the circular shape of the operation side 10a, i.e., an about 26 cm diameter, and has an arc length of about 8.5 cm. A direction of the arc on the left side 10b substantially agrees with a specific direction (upward direction in FIG. 1) of the analog direction key 12. Accordingly when a player holds the controller body 10, he can know the upward direction of the analog direction key 12 by the touch of his palms, and can play a game without looking at the controller. To enable a player to comfortably operate the controller, it is preferable that the arc of the left side 10b has a diameter of about 18 - 34 cm and an arc length of about 6 - 11 cm.

When a player operates the controller according to the present embodiment, gripping it with the hands, as shown in FIG. 4, the edge of the operation side 10a of the controller 10 is held with both hands. To enable a player to comfortably hold the controller with both hands, it is preferable that the controller body 10 has an about 2-4 cm thickness, and the parts of the controller body 10 where the command levers 22l, 22r are disposed have an about 4- 8 cm thickness, which is about twice the thickness of the controller body 10.

When a player grips the controller with both hands, the thumb of the left hand operates the analog direction key 12 or the digital direction key 14 on the front side, and the index or middle finger of the left hand operates the command lever 22l on the back side, while the thumb of the right hand operates the command buttons 20x, 20y, 20z, 20a, 20b, 20c on the front side, and the index or middle finger of the right hand operates the command lever 22r on the back side.

When the analog direction key 12 and the digital direction key 14 are operated, as shown in FIG. 4, the left side 10b is gripped by the left hand with the arcuate portion of the left side 10b held by the palm of the left hand, whereby direction commands can be made, with a reference direction of the analog direction key 12, kept in mind.

Especially, since the analog direction key 12 does not respond with click touch, as does the digital direction key 14, a player will be at a loss as to his operation direction without the left side 10b. Thus it is very significant to provide the left side 10b with the curved portion having a large diameter.

As to the digital direction key 14, although it is pos-

sible to know a command direction of the digital direction 14 based on click touch alone, the presence of the flat left side 10b ensures that a player knows his operation direction without failure.

As shown in FIG. 3, the expansion unit 30 is mounted in the center of the back side of the controller body 10. The expansion unit 30 is inserted between the controller 10 and the game device 200, and supplies command signals from the controller body 10 produced by operating the various operation keys on the controller body 10. The expansion unit 30 is removable from the controller body 10 to be replaced as required.

The controller with the expansion unit 30 mounted on has the central portion of the controller body 10 projected as shown in FIG. 3. Controllers are usually handled roughly. When the controller is dropped or hit against other objects, the command levers 22l, 22r are disposed on the operation sides 10c, 10d in hollows formed by the expansion unit 30 projected from the back side of the controller body 10, to be protected from direct impacts.

FIG. 5 shows the controller body 10 with the expansion unit 30 removed therefrom. The expansion unit 30 has a male connector 31 on the end to be connected to the controller body 10, and the controller body 10 has a female connector 26 for expansion on the rear side of the controller body 10. The connector 26 for expansion is the end of a circuit substrate (not shown) disposed inside the controller. When the expansion unit 30 is mounted, the male connector 31 is connected to the female connector 26 for expansion of the controller body 10.

As shown in FIG. 6B, the connector 31 of the expansion unit 30 has the shape of a male connector and includes ten pins P1 - P10. The upper row of the pins includes, from the left, a first pin P1, a third pin P3, a fifth pin P5, a seventh pin P7 and a ninth pin P9, and the lower row of pins includes, from the left, a second pin P2, a fourth pin P4, a sixth pin P6, an eighth pin P8 and a tenth pin P10.

The connector 26 for expansion of the controller body 10 has the shape of a female connector as shown in FIG. 6A and includes two rows of pins. The upper row of the pins includes, from the left, a ninth pin P9, a seventh pin P7, a fifth pin P5, a third pin P3 and a first pin P1, and the lower row of the pins includes, from the left, a tenth pin P10, an eighth pin P8, a sixth pin P6, a fourth pin P4 and a second pin P2.

Function of the Controller

Next, the function of the controller according to the present embodiment will be explained with reference to FIGs. 7 and 8. FIG. 7 is a block diagram containing an expansion unit 30 mounted thereon, having no additional expansion functions, and FIG. 8 is a block diagram containing an expansion unit 40 mounted thereon, having additional expansion functions.

As shown in FIGs. 7 and 8, the controller body 10 includes a control computer 24 for general control. The control computer 24 detects operation signals from the analog direction key 12, the digital direction key 14, the start button 16, the command buttons 20x, 20y, 20z, 20a, 20b, 20c and the command levers 22l, 22r, and outputs the operation signals in accordance with the operation mode selected by the change-over switch 18. The controller body 10 includes an expansion connector 26 for connecting the expansion unit 30.

As shown in FIG. 7, the expansion unit 30, which adds no expansion functions, includes a connector 31 for connecting the expansion unit 30 to the controller body 10, and a signal line from the connector 31 is connected to a connection cable 32. A connector 33 to be connected to the connector 202 of the game apparatus body 200 is provided at the end of the connection cable 32.

The expansion unit 30 is inserted between the controller body 10 and the game apparatus body 200 and outputs command signals as they are received from the controller body 10 to the game apparatus body 200.

As shown in FIG. 8, the expansion unit 40, which adds expansion functions, includes the control computer 44 for general control, which is connected to a function expansion unit 45 for realizing functions to be expanded. The expansion unit 40 includes a connector 41 for connecting to the expansion connector 26 of the controller body 10 as does the standard expansion unit 30, and a connector 43 to be connected to a connector 202 of the game apparatus body 200 is provided on the end of the connection cable 42.

The expansion unit 40 is inserted between the controller body 10 and the game apparatus body 200, and the control computer 44 combines command signals expanded by the function expansion unit 45 with command signals from the controller body 10 and outputs them to the game apparatus body 200.

FIG. 9 shows a pin arrangement of the connector 41 of the expansion unit 40, and a pin arrangement of the expansion unit 26 of the controller body 10.

For both connectors 41, 26, the fourth pin P4, the fifth pin P5, and the sixth pin P6 are used mainly as control lines. The fourth pin P4 is used as the control line for select signals (TH) from the expansion unit 40 to the controller body 10, the fifth pin P5 is used as the control line for request signals from the expansion unit 40 to the controller body 10, and the sixth pin P6 is used as the control line for response signals (TL) from the controller body 10 to the expansion unit 40.

The seventh pin P7, the eighth pin P8, the second pin P2, and the third pin P3 are used mainly as data lines. The seventh pin P7 is used as the data line for bit 3 data signals (R), the eighth pin P8 is used as the data line for bit 2 data signals (L), the second pin P2 is used as the data line for bit 1 data signals (D), and the third pin P3 is used as the data line for bit 0 data signals (U).

Furthermore, the first pin P1 is used as an electric

power source line (VCC), and the ninth pin P9 is used as a ground line (GND).

Then, with reference to FIG. 10, conversion of command signals from the controller body by the expansion unit will be explained.

As shown in FIG. 10A, each of the command signals from the controller body 10 includes identification codes ID1-ID4, and data DATA following the identification codes ID1-ID4, and an end code END which indicates the end of the command signals.

In the case of FIG. 7 in which the expansion unit 30 having no expansion functions is connected, command signals shown in FIG. 10A are outputted as they are to the game apparatus body 200. The game apparatus body 200 determines the type of the connected controller, based on the identification codes ID1-ID4 and receives the following data signals DATA.

In the case of FIG. 8 in which the expansion unit 40 having expansion functions is connected, the command signals shown in FIG. 10A are outputted by the controller body 10, but the identification codes ID3, ID4 are changed by the control computer 44 of the expansion unit 40 to controller identification codes ID3', ID4', as shown in FIG. 10B, which identify the controller as having expansion functions. The game apparatus 200 determines the type of the connected controller, based on the identification codes ID1 - ID4' and receives the data signals DATA.

FIGs. 10C and 10D show examples of the command signal changing process. The controller body 10 outputs identification codes 1114 and data FFFF following the identification codes as shown in FIG. 10C, and the control computer 44 changes the identification signals to identification signals 1166 and adds data 88 after the data FFFF as shown in FIG. 10D.

The advantages of the expansion unit for the controller according to the present embodiment will be explained in comparison of the block diagram of the controller according to the present embodiment shown in FIGs. 7 and 8 to the block diagram of the conventional controller shown in FIG. 11.

In the conventional controller, as shown in FIG. 11, the connector 28 is disposed on the end of the connection cable 27 of the controller body 10, and the connector 28 is connected to the connector 202 of the game apparatus body 200. The expansion connector 26 is provided independently of the connection cable 27 for connection of the expansion unit 300, and the expansion connector 26 is connected to the control computer 24. The connector 302 of the expansion unit 300 is connected to the expansion connector 26 to connect the expansion unit 300 to the controller body 10.

The expansion unit of the conventional controller is connected to the controller computer 24 and is under the control thereof as described above. To this end it is necessary that the control computer 24 knows in advance details of functions of the expansion unit 300 connected to the expansion connector 26, e.g., identifi-

cation numbers, etc. indicative of the connected expansion functions. This is because it is necessary that when the expansion unit 300 is connected, a type, etc. of the expansion unit 300 are supplied to the game apparatus body 200 through the connection cable 27. That is, conventionally a connectable type of the expansion unit 300 must be determined when the controller body 10 is designed, and the expansion unit 300 of a type other than the intended type when originally designed cannot be connected.

In contrast to the conventional controller arrangement, in the present embodiment, as shown in FIG. 8, the expansion unit 40 is inserted between the controller body 10 and the game apparatus body 200, and the expansion unit 40 processes command signals from the controller body 10 to supply the same to the game apparatus body 200. The control computer 24 of the controller body 10 only supplies its own command signals. This is because the control computer 44 of the expansion unit 40 conducts processing in connection with expansion functions of its own expansion unit 40. Accordingly, new functions which are not intended when the controller body 10 was designed can be optionally added.

Furthermore, the expansion unit for the controller according to the present embodiment is advantageous in comparison to the case where a new controller having new functions is designed and provided. In designing a new controller, basic command keys, such as direction keys, command keys, etc., are necessary for game operation and are absolutely necessary to retain compatibility with the concurrent controller. It is frequent cases that in addition to the basic command keys, such as direction keys and command buttons, etc., command keys for realizing new functions are added. To this end a new controller including the basic command keys must be redesigned, which makes a fast design impossible and adds to the design costs.

In contrast to this, in the present embodiment, the basic command keys are controlled by the controller body 10, so that the expansion unit can be designed in consideration of only new functions. This can reduce design costs and development time.

Examples of the Expansion Unit

Various examples of the expansion unit will be explained with reference to FIGs. 12 to 34.

Cordless Expansion Unit

An expansion unit 50 shown in FIGs. 12 and 13 realizes a cordless expansion unit by the use of infrared signals.

The expansion unit 50 which adds the cordless function includes a connector 51 to be connected to the expansion connector 26 of the controller body 10 just as the standard expansion unit 30 is. The expansion unit

50 also includes a control computer 53 for general control and the control computer 53 has a light emitting unit 52.

The control computer 53 outputs command signals from the controller body 10 as photo signals using the light emitting unit 52. A light detecting unit 204 of a game apparatus body 200 detects the photo signals from the light emitting unit 52 and decodes the photo signals into command signals.

The expansion unit is thus attached, whereby simply the controller is made cordless.

Photo Signal Detecting Expansion Unit

An expansion unit 60 shown in FIGs. 12 and 14 is for adding the function of detecting photo signals from the outside, e.g. the video monitor (not shown).

The expansion unit 60 which adds the photo signal detecting function includes a connector 61 to be connected to the expansion connector 26 of the controller body 10 just as the standard expansion unit 30 is, and includes on the end of a connection cable 62 a connector 63 to be connected to a connector 202 of a game apparatus body 200. The expansion unit 60 includes a control computer 64 for the general control and the control computer 64 includes a photo detector 65.

Signals detected by the photo detector 65 are combined with command signals from the controller body 10 by the control computer 64 and supplied to a game apparatus body 200.

The photo detector 65 thus detects photo signals from the outside, e.g. video monitor, whereby shooting games in which enemies in monitor screens are shot can be played.

Vibration Expansion Unit

An expansion unit 70 shown in FIGs. 12 and 15 adds the function of giving vibrations to the controller body 10.

The expansion unit 70 which adds the vibration function includes a connector 71 to be connected to the expansion connector 26 of the controller body 10 just as the standard expansion unit 30 is, and a connector 73 to be connected to a connector 202 of a game apparatus body 200 is provided on the end of a connection cable 72. An electric power source 76 for giving vibrations is disposed in the connection cable 72. The expansion unit 70 includes a control computer 74 for the general control, and the control computer 74 includes a vibration unit 75 for giving vibrations.

The vibration unit 75 is actuated in response to a command signal from the game apparatus body 200 or the controller body 10 and gives vibrations to the controller body 10.

Vibrations are thus given to the controller body 10 from the vibration unit 75, whereby vibrations are given upon shooting, and realistic games can be enjoyed.

Joy stick Expansion Unit

An expansion unit 80 shown in FIGs. 16 and 17 adds a joy stick as a new operation key to the controller body 10.

In FIG. 16, the expansion unit 80 which adds the joy stick is attached to the rear side of the controller body 10. The expansion unit 80 includes a connector 81 to be connected to the expansion connector 26 of the controller body 10 just as the standard expansion unit 30 is, and a connector 83 to be connected to a connector 202 of a game apparatus body 200 is provided on the end of a connection cable 82. The expansion unit 80 includes a control computer 84 for the general control, and the control computer 84 includes the joy stick 85.

When a player operates the joy stick, operation signals are combined with command signals from the controller body and are supplied to the game apparatus body 200.

The joy stick 35 is thus used as a new operation key, and operations can be made suitable for games.

In FIGs. 18 and 19, the expansion unit 80 which adds the joy stick is attached to the left side of the controller body 10.

The expansion unit 80 is secured to the controller body 10 by means of a screw hole 87 engaged in a screw hole 29 in the back side of the controller body 10. Command buttons 86a, 86b are provided above the joy stick 85 as viewed in FIG. 17.

When the expansion unit 80 is attached, the joy stick 85 is positioned on the left side of the analog direction key 12 and the digital direction key 14, which improves the ease of operation.

Track Ball Expansion Unit

An expansion unit 80 shown in FIGs. 20 to 23 adds a track ball as a new operation key to the controller body 10.

In FIG. 20, the expansion unit 80 which adds a track ball is attached to the rear side of the controller body 10. The expansion unit 80 includes the track ball 88 in place of the joy stick 85. When a player operates the track ball, operation signals are combined with command signals from the controller body 10 and are supplied to a game apparatus body 200.

The track ball 88 is thus used as a new operation key to make operations suitable for games.

In FIGs. 22 and 23, the expansion unit 80 which adds a track ball is attached to the front side of the controller body 10.

The expansion unit 80 is secured to the controller body 10 by means of a screw 87 engaged in a screw hole 29 in the back side of the controller body 10. A decision button 89a and a cancel button 89b are provided above the track ball 88 as viewed in FIG. 22.

When the expansion unit 80 is thus attached, the track ball 88 is positioned in front of the controller body

10, which improves the ease of operation.

Memory Expansion Unit

An expansion unit 90 shown in FIGs. 24 and 25 adds a memory module 96 to the controller body 10.

The expansion unit 90 which adds the memory module 96 includes a connector 91 to be connected to the expansion connector 26 of the controller body 10, and a connector 93 to be connected to a connector 202 of a game apparatus body 200 is provided on the end of a connection cable 92. The expansion unit 90 includes a control computer 94 for the general control, and the control computer 94 includes a memory slot 95. The memory module 96 is engaged in the memory slot 95.

The memory module 96 can be used in various ways. For example, information from the game apparatus body 200 or the controller body 10 may be stored. In addition, information to the game apparatus body 200 or the controller body 10 may also be stored.

The memory is thus added, whereby functions of the game apparatus can be enhanced.

Display Expansion Unit

An expansion unit 100 shown in FIGs. 26 and 27 adds an image display unit 105 to the controller body 10.

The expansion unit 100 which adds the image display unit 105 includes a connector 101 to be connected to the expansion connector 26 of the controller body 10, and a connector 103 to be connected to a connector 202 of a game apparatus body 200 is provided on the end of a connection cable 102. The expansion unit 100 includes a control computer 104 for the general control, and the control computer 104 includes the image display unit 105. As shown in FIG. 26, the image display unit 105 is positioned so it can be viewed by a player operating the controller body 10.

The image display unit 105 can be used in various ways. For example, the image display unit 105 may display information from either the game apparatus body 200 or the controller body 10.

The image display unit 105 is thus added, whereby functions of the game apparatus can be enhanced.

Clock Expansion Unit

An expansion unit 110 shown in FIGs. 28 and 29 adds a clock function to the controller body 10.

The expansion unit 110 for adding the clock function includes a connector 111 to be connected to the expansion connector 26 of the controller body 10 just as the standard expansion unit 30, and a connector 113 to be connected to a connector 202 of a game apparatus body 200 is provided on the end of a connection cable 112. The expansion unit 110 includes a control computer 114 for the general control. The control computer 114

includes a clock unit 116 for counting time and outputs a correct current time. The clock unit 116 includes a time display unit 115. The time display unit 115 displays a current time, etc. outputted by the clock unit 116. As shown in FIG. 28, the time display unit 115 is positioned so it can be viewed by a player operating the controller body 10.

The clock unit 116 outputs to the game apparatus body 200 a current time, the length of time that the controller has been connected to the game apparatus body 200, the time when a game is started, etc., and can be used for timing event occurrences in a game.

The clock function is thus added, whereby functions of the game apparatus can be enhanced.

Handle Expansion Unit

An expansion unit 120 shown in FIGs. 30 to 32 makes use of the circular shape of the controller body 10 to use the controller body 19 as a handle (rotational control).

As shown in FIG. 30, the expansion unit 120 that adds the handle function includes a support base 126, and a handle shaft 127 is projected from the support base 126. The handle shaft 127 can be rotated, and the controller body 10 is secured to the handle shaft 127 by means of a screw. As shown in FIG. 31, a rotary angle detector 125 detects the rotation angle of the handle shaft 127 and outputs the angle to a control computer 124.

As shown in FIG. 32, when a player operates the controller body 10 as a handle, operation signals are combined with command signals from the controller body 10 and are supplied to the game apparatus body 200.

The controller body 10 is thus used as a handle to make operations suitable for games.

Inclination Detection Expansion Unit

An expansion unit 130 shown in FIGs. 33 and 34 adds the function of detecting the inclination of the controller body 10.

The expansion unit 130 which adds the function of an inclination includes a connector 131 to be connected to the expansion connection of the controller body 10 just as the standard expansion unit 30 is, and a connector 133 to be connected to a connector 202 of a game apparatus body 200 is provided on the end of a connection cable 132. The expansion unit 130 includes a control computer 134 for the general control, and the control computer 134 includes an inclination detecting unit 135. The inclination detecting unit 135 detects an inclination angle of the controller body 10. Detected signals of the inclination detecting unit 135 are combined by the control computer 134 with command signals from the controller body 10 and are outputted to the game apparatus body 200.

The detected signal of the inclination detecting unit 135 can be used in various ways. For example, in the game shown in FIG. 20, in which an airplane is operated, the control is made so that the airplane is tilted by an inclination of the controller body 10.

As described above, according to the present embodiment, expansion units can be attached to the conventional controller, whereby the controller can have optional additional functions. In the present embodiment, the expansion unit is inserted between the game apparatus body and the controller body and, based on expanded functions, command signals from the controller body are changed by the expansion unit, and supplied to the game apparatus body, whereby completely new functions can be optionally added without making changes to the controller body.

Second Embodiment

The controller according to a second embodiment will be explained with reference to FIGs. 35 to 37. FIG. 35 is a plan view of the controller according to the present embodiment. FIG. 36 is a front view of the controller according to the present embodiment. FIG. 37 is a right side view of the controller according to the present embodiment. The same members and members of the same kinds of the present embodiment as those of the first embodiment are represented by the same reference numerals in order not to repeat their explanation.

The controller according to the present embodiment is the same as the first embodiment in that the basic shape of the outside edge of a controller body 10 is circular, and includes two lugs 11l, 11r projected toward a player holding the controller body 10.

In the first embodiment, the left side of the controller body 10 is formed in a larger-diameter arcuate portion so that when a player grips the controller body 10, he can know the upward direction of an analog direction key 12 by the touch of the palm. In the present embodiment, because of the lug 11l, the controller body 10 has substantially the same shape on both the left and right sides. A player knows the upward direction of the analog direction key 12 by touching the lugs 11l, 11r.

When a player holds the lugs 11l, 11r with his hands, he operates: the analog direction key 12 or a digital direction key 14 on the surface of the controller body 10 with the left thumb, the command lever 221 with the left index or middle finger, the command buttons 20x, 20y, 20z, 20a, 20b, 20c on the surface of the controller body 10 with the right thumb, and the command lever 22r on the back side with the right index or middle finger.

In the present embodiment, as shown in FIG. 35, conical grooves are formed in the top surface of the analog direction key 12 with no cross pattern. The analog direction key 12 can indicate all directions, and even if a cross pattern is formed, the direction of the cross pattern does not always agree with a direction indicated

by the analog direction key 12. The cross pattern may rather puzzle players. This is why the conical grooves alone are formed. The conical grooves act as an anti-slipping means in operating the analog direction key 12.

Thus, according to the present embodiment, the lugs make the controller convenient for a player to grip during operation.

Inclination Detection Expansion Unit with Vibration Function

As an example of the expansion unit of the present embodiment, an inclination detection expansion unit with a vibration function will be explained with reference to FIGs. 38 to 42. FIG. 38 is a perspective view of the present expansion unit. FIG. 39 is back side view of the present expansion unit removed from the controller body. FIG. 40 is an exploded perspective view of the present expansion unit. FIG. 41 is a block diagram of the present expansion unit. FIG. 42 comprises views explaining an operation of the present expansion unit.

The inclination detection expansion unit with vibration function 140 adds the function of detecting an inclined state of the controller body 10 and the function of vibrating the controller body 10.

As shown in FIG. 38, as does the standard expansion unit 30, the expansion unit 140 includes a connector 141 to be connected to the expansion connector 26 of the controller body 10, and a connector 143 to be connected to the connector 202 of the game apparatus body 200 is provided on an end of a connection cable 142. As shown in FIG. 39, the expansion unit 140 is mounted on the back side of the controller body 10.

A structure of the inclination detection expansion unit with vibration function will be detailed with reference to FIG. 40. The expansion unit 140 includes a main circuit substrate 150. A connector substrate 151 is connected to one end of the main circuit substrate 150. An acceleration sensor 152 and a microcomputer 153 are mounted on the main circuit substrate 150. The acceleration sensor 152 can detect a rotation angle (a roll angle and a pitch angle) from an initial position. The main circuit substrate 150 is connected to a vibration motor 154. A semi-circular eccentric weight 154 is mounted on the rotary shaft of the vibration motor 154, and when the vibration motor 154 is rotated, vibrations are generated by the eccentric weight 154a.

The main circuit substrate 150 is secured to the case 155. The vibration motor 154 is fit in the box 155a in the case 155. The connector substrate 151 is secured to a case 156. The case 155 is covered by a case 157 with the connection cable 142 therebetween.

A function of the inclination detection expansion unit with vibration function 140 will be explained with reference to FIG. 41. The expansion unit 140 includes a control computer 144 for general control. The control computer 144 includes an inclination detection unit 145 and a vibration unit 146.

The control computer 144 includes a microcomputer 153 and generally controls the expansion unit 140. The inclination detection unit 145 includes the acceleration sensor 152 and detects an inclination angle of the controller body 10. A detection signal of the inclination detection unit 145 is combined by the control computer 144 with a command signal from the controller body 140 to be supplied to the game apparatus body 200. The vibration unit 146 includes a vibration motor 154 and vibrates, based on a vibration command signal from the game apparatus body 200 or the controller body 10 to give vibrations to the controller body 10. Source electric power of the vibration motor 154 is supplied by the game apparatus body 200.

Next, the inclination detecting function will be detailed.

By mounting the expansion unit 140 on the controller body 10, an inclination angle of the controller can be detected. An inclination angle is represented by a rotation angle (a roll angle and a pitch angle) on the controller. A roll angle TX is represented as shown in FIG. 42A; as viewed at the back of the controller, when a central roll angle TX is 80h, a rightmost roll angle TX is 00h, and a leftmost roll angle TX is FFh. A pitch angle is represented as shown in FIG. 42B; as viewed sideways, when a forward pitch angle TY is 80h, a lowermost pitch angle TY is 00h, and an uppermost pitch angle TY is FFh.

Accordingly, when the controller is tilted right, the roll angle TX is decreased, and the roll angle TX is increased when the controller is tilted left. When the controller is tilted downward, the pitch angle TY is decreased, and the pitch angle TY is increased when the controller is tilted upward.

An inclination angle of the inclination detection unit 145 is automatically centered on prescribed occasions while the controller is positioned in the central direction (a roll angle TX=80h, a pitch angle TY=80h). An inclination angle is automatically centered, e.g. when source electric power is supplied to the game apparatus body 200, the controller is connected to the game apparatus body 200, source electric power is supplied to the expansion unit 140, a mode is changed by operation of the change-over switch 18 of the controller body 10, the expansion unit 140 is connected to the controller body 10, or a reset signal is supplied from the game apparatus body 200.

An inclination angle has an insensitive range so that the controller does not react to a slight change of the inclination angle, and when an inclination angle changes by <12 degrees, the controller judges that no inclination has taken place. It is possible that an insensitive range of an inclination angle is changeable in response to a signal from the game apparatus body 200. Inclination sensitivity can be adjusted in accordance with a game.

It is also possible that a signal indicative of an inclination angle of the inclination detection unit 145 is

replaced by a command signal from the analog direction key 12 or a digital direction key 14 by changing a mode. This operation can be made by changing an inclination of the controller in place of operating the analog direction key 12 or the digital direction key 14.

Next, the vibration function will be detailed.

The expansion unit 140 is connected to the controller body 10, whereby vibrations can be given to the controller. An intensity of the vibrations can be set by a signal from the game apparatus body 200. The intensity can be adjusted to be, e.g., 8 stages from a vibration intensity = 0 (no vibration) to a vibration intensity = 7.

To ensure safety upon the vibration, source electric power of the vibration motor 154 is supplied by the game apparatus body 200, so that the vibration is stopped by disconnecting the connector 143 of the expansion unit 140 from the game apparatus body 220. The vibration is forcibly stopped when no signal is outputted from the game apparatus body 200 within a prescribed period of time. Thus a danger that the vibration is not stopped when the game apparatus body 200 is hung up or when the reset switch is pressed can be prevented. The vibration is forcibly stopped when a mode is changed by the change-over switch 18 of the controller body 10.

The inclination detection expansion unit with vibration function of this example has a wide variety of uses. For example, the inclination detecting function is used, and the controller itself is operated as the steering wheel of a car. It is possible that the vibration function is used to give trivial vibrations when the car is driven on a bad road, and strong vibrations are given when the car collides. It is also possible that the inclination detecting function is used to operate the controller itself as the column of an airplane. The vibration function may be used to give trivial vibrations for landing of the airplane, and strong vibrations may be given when the airplane is shot.

Third Embodiment

The controller according to a third embodiment of the present invention will be explained with reference to FIGs. 43 to 50. FIG. 43 is a plan view of the controller according to the present embodiment. FIG. 45 is a right side view of the controller according to the present embodiment. FIG. 46 is a bottom view of the controller according to the present embodiment.

As shown in FIG. 43, two grips 512l, 512r for a player to hold with the hands are extended from a controller body 510 toward the player. A connection cable 514 to be connected to a game apparatus body (not shown) is provided at the center of the side opposite to the grips 512l, 512r of the controller body 510.

A start button 516 is provided at the lower central part of an operational surface 510a which is the upper surface of the controller body 510. A direction key 518 for commanding directions is provided on the left side of

the operational surface 510a. Six command buttons 520x, 520y, 520z, 520a, 520b, 520c are provided on the right side of the operational surface 510a.

As shown in FIG. 44, a bulge 510b is provided at the central back side of the controller body 510. The bulge 510b and the two grips 512l, 512r enable the controller body 510 to be mounted stably on a flat surface, as of a table or the like. Parts of the back side of the controller body 510, which are on both sides of the bulge are recessed, and command levers 522l, 522r are provided on operational surfaces 510c, 510d which are the recessed parts on both sides of the bulge 510b.

Further, on the operational surface 510c which is the back side of the controller 510 there is provided a change-over switch 524 for switching functions of a cross key 518.

Thus, the controller according to the present embodiment includes the start button 516, the direction key 518 and the command buttons 520x, 520y, 520z, 520a, 520b, 520c on the operational surface 510a which is the upper surface, and includes the command levers 522l, 522r and the change-over switch 524 on the operational surfaces 510c, 510d which are the back side of the controller.

The start button 516 is a command button of the type that one command can be inputted by once pressing the start button. The start button is disposed at the lower central part of the upper surface, which makes it difficult to frequently press the start button. The start button is used to make commands, such as a start command for starting a game, or others, which do not require pressing the start button during a game.

The direction key 518 of the present embodiment can make direction commands for 8 preset directions which are spaced from each other, the so-called digital direction commands, and also make continuous direction commands which command all the directions over 360°, the so-called analog direction commands. The direction key 518 is disposed on the left side of the operational surface 510a on the upper surface and is usually operated by the left thumb of a player.

A mechanism of the direction key 518 will be detailed with reference to FIG. 47. The direction key 518 is in the form of a circular operational plate 530 appearing on the operational surface 510a. On the upper surface of the operational plate 530, a cross-shaped relief is formed as a mark for facilitating a player knowing an operational direction. The operational plate 530 is connected to a circular plate 534 provided beneath the operational surface 510a. The circular plate 534 is integral with the operational plate 530 and moves with the operational plate 530.

On the underside of the circular plate 534 there are provided convexities 535 at positions corresponding to four directions: the upward, downward, left and right directions. A base plate 536 is provided below the circular plate 534, and rubber switches 538 are provided at positions opposed to the convexities 535 on the circular

plate 534.

When a player operates to tilt the operational plate 530 in one direction, the associated convexity 535 presses down the associated rubber switch 538 to short-circuit an electrode pattern (not shown) on the base plate 536 to detect the operational direction. When the operational plate 530 is tilted in one of the upward, downward, left and right directions, the associated rubber switch 538 is pressed down, whereby the four directions can be detected. When the operational plate 530 is tilted in a direction between the upward, downward, left and right directions, and their adjacent directions, two rubber switches are pressed down together, and in total eight directions including the upward, downward, left and right directions can be detected.

Sectoral encoders 540 are provided on the circular plate 534 at the ends of two directions crossing each other. Each encoder 540 has holes 540a opened at a certain interval along the peripheral edge thereof. As shown in FIG. 47, the sectoral encoders 540 are moved up and down in the vicinity of the rod 532 corresponding to an inclination of the circular plate 534. Photo-interrupters 542 are disposed, holding the peripheral edges of the respective encoders 540.

Each photo-interrupter 542 includes a light emitting device (not shown) and a photo-detecting device (not shown), and detects presence and absence of an object in an optical path between the light emitting device and the photo-detecting device. When the encoder 540 is moved up and down, the associated photo-interrupter 542 detects passing of the holes 540a to detect vertical positions of the encoder. The encoders 540 are disposed along two directions of the circular plate 534, which cross each other. Based on vertical positions of the two encoders 540, a direction of tilt of the circular plate 543 can be known. Thus an arbitrary direction of the operational plate 530 operated by a player can be detected, and all directions over 360° can be commanded.

As described above, the direction key 518 of the present embodiment can make not only 8 digital direction commands, but also all analog direction commands over 360°. The digital direction command and the analog direction command can be changed over to each other by the change-over switch 524 provided on the back side of the controller body 510.

The command buttons 520x, 520y, 520z, 520a, 520b, 520c are of the type that one command can be inputted by once pressing them, as is the start button 516. The command buttons 520x, 520y, 520z, 520a, 520b, 520c are disposed on the right side of the upper surface of the operational surface 510a and are operated usually by the right thumb of an operator.

The command levers 522l, 522r are pulled forwards to input command amounts which are continuously changed. The command levers 522l, 522r are disposed on the left and the right operational surfaces 510c, 510d of the back side. As shown in FIG. 49, the command

levers 522l, 522r are pulled forwards by, e.g., the index fingers or the middle fingers when a player holds the controller with the grips 512l, 512r with the left and the right hands.

Mechanisms of the command levers 522l, 522r will be explained with reference to FIGs. 46 and 48. The mechanisms of the command levers 522l, 522r are the same except that they are horizontally symmetrical to each other, and the command lever 522l shown on the right side in FIG. 46 will be explained. FIG. 48 comprises explanatory views of component members of the command lever 522l, which explain their relationships and show the mechanism of the command lever 522l as viewed on the right side.

As shown in FIG. 46, the command levers 522l, 522r have operational levers 550 which are projected beyond the operational surface 510c. As shown in FIG. 48B, the operational lever 550 includes a shaft 550b provided at the root of a sectoral operational portion 550a, and the shaft 550b is bent at a right angle. The operational portion 550a of the operational lever 550 is pulled forwards and is rotated on the shaft 550b.

A detection mechanism for detecting an operational angle of the command lever 522l is disposed in the bulge 510b of the controller body 510. The detection mechanism includes a sectoral gear, a circular encoder 554 and a photo-interrupter 556l.

The sectoral gear 552 has teeth formed in the arcuate periphery, and a shaft 552a disposed at the center thereof. The shaft 552a is bent at a right angle and further at a right angle. The sectoral gear 552 is rotated on the shaft 552a.

An end 552b of the shaft 552a of the sectoral gear 552 abuts upon an end 550c of the shaft 550b, and when the operational lever 550 is rotated on the shaft 550b, the end 550c of the shaft 550b pushes the end 552b of the sectoral gear 552 to rotate the sectoral gear 552.

As shown in FIG. 48A, the circular encoder 554 has holes 554a formed in the peripheral edge at a certain interval. The circular gear 554b is formed on the center of the circular encoder 554. As shown in FIG. 48A, the circular gear 554b is in mesh with the sectoral gear 552, and when the sectoral gear 552 is rotated, the circular encoder 554 is rotated through the circular gear 554b.

A photo-interrupter 556l is disposed, holding the circular encoder 554 therebetween, and passing of the holes 554a in the circular encoder 554 is detected to detect rotation angles of the circular encoder 554 and rotation angles of the operational lever 550. The command levers 522l, 522r are thus operated to supply continuously changing command amounts corresponding to rotation angles of the operational lever 550, which cannot be supplied by the command buttons 520x, 520y, 520z, 520a, 520b, 520c.

When a player operates the controller according to the present embodiment, holding the controller with the hands as shown in FIG. 49, the left and the right grips

512 of the controller body 510 are held by the left and the right hands. The left hand operates the direction key on the surface with the thumb, and the command lever 522l on the back side with the index finger or the middle finger. The right hand operates the command buttons 520x, 520y, 520z, 520a, 520b, 520c on the surface with the thumb, and the command lever 522r on the back side with the index finger or the middle finger. As described above, according to the present embodiment, continuously changing commands can be made, which the conventional controller has found impossible, and commands of arbitrary directions and commands of continuously changing directions can be made. The command levers provided on the back side of the controller allow more complicated commands to be made. Furthermore, complicated commands can be made relatively easily with the grips stably held.

When the controller according to the present embodiment is placed on a flat surface, such as a desk, with three points of the bulge 510b and the grips 512l, 512r supported on the flat surface, the controller can be operated in a stable state. When the controller is placed on a flat surface, such as a desk, as shown in FIG. 45, the operational surface 510a, which is the upper surface of the controller with the direction key 510 and the command buttons 520x - 520c provided on, is parallel with the flat surface, such as the desk, which enables a player to easily operate the direction key 518 and the command buttons 520x - 520c.

When the controller is placed on a desk or the like, as shown in FIG. 45, the command levers 522l, 522r do not abut on the desk and define a space which allows the controller to be operated with fingers, and the command levers can be easily operated with both hands placed on the grips 512l, 512r.

It is often that the controller is roughly handled, and because of the command levers 522l, 522r are disposed in the operational surfaces 510c, 510d which are cavities beside the bulge 510b on the back side of the controller body 510, even when the controller is dropped or is hit against another object, the command levers 522l, 522r are prevented from direct impact.

Next, a circuit diagram of the controller according to the present embodiment will be explained with reference to the block diagram of FIG. 50.

For the digital direction command by the direction key 514, an upper contact 538a, a lower contact 538b, a left contact 538c and a right contact 538d are constituted by the rubber switch 538, and correspond to the upward and the downward directions and the left and the right directions. Outputs from the respective contacts 538a - 538d are inputted to direction key direction determining means 560. Based on the outputs, the direction key direction determining means 560 determines a direction of an inclination of the operational plate 530 commanded by the direction key 514.

On the other hand, for the analog direction command by the direction key 514, photo-interrupters 542a,

542b are disposed in directions of the circular plate 534 crossing each other. The photo-interrupters 542a, 542b respectively include counting means 562a, 562b for counting numbers of holes 540a of encoders 540, which have passed. Based on counted values given by the counting means 562a, 562b, direction key inclination direction computing means 564 computes an inclination direction of the circular plate 534 commanded by the direction key 514. A most inclined direction is a commanded direction.

Output from the direction key determining means 560 or the direction key inclination direction computing means 564 is selected by change-over switch 524 to be inputted to data input/output control unit 570.

An output of the start button 516 is inputted directly to the data input/output control unit 570.

The photo-interrupter 556l of the command lever 522l and the photo-interrupter 556r of the command lever 522r respectively include counting means 566l, 566r, and count numbers of holes 554a in circular encoders, which have passed. Based on counted values given by the counting means 566, command lever angle computing means 568 compute rotation angles of the operational levers 550 commanded by the command levers 522.

Computed outputs from the command lever angle computing means 568l, 568r are inputted to data input/output control unit 570.

Outputs of the command buttons 520x, 520y, 520z, 520a, 520b, 520c are inputted directly to the data input/output control unit 570.

The data input/output control unit 570 receives signals from the above-described component members to select necessary data corresponding to a data request outputted by the game apparatus body 600 and supplies the data to the game apparatus body 600 through the cable 514.

Source electric power of the entire controller is supplied by the game apparatus body 600 through the cable 514.

As described above, according to the present embodiment, the command lever is operated to make continuously changing commands which has been impossible in the conventional controller. Arbitrary direction commands can be made by detecting an inclination direction of the operational plate. Furthermore, the command levers are disposed on the operational surface, which is the back side of the controller, so that when the controller is held with the hands, the command levers can be operated with the index fingers and middle fingers, and can be easily subtly operated.

The controller according to the present embodiment can realize natural and comfortable operational feelings in games on which the conventional controller has found it difficult. In a racing game, for example, the direction key is used in steering a wheel, the command buttons are used in the gear shift operation and the shift lever operation, the left command lever is used in brak-

ing, and the right command lever is used in acceleration, whereby subtle operations can be realized with natural feelings.

Modified Embodiments

The present invention is not limited to the above-described embodiments and covers other various modifications.

For example, the expansion units described in the first and second embodiments are examples and may include those embodiments which add other functions.

The direction key of the controller may have a mechanism other than the above-described mechanism of the third embodiment to detect an inclination direction of the direction key. It is also possible to detect an arbitrary angle, based on a direction of an inclination of an operational unit, such as a joy stick.

In the above-described third embodiment, the digital direction command and the analog direction command by the direction key are interchanged by the change-over switch, but it is possible that the change-over switch is not provided, and the key direction itself is operated to change over the digital and analog direction command. It is also possible that data of both a digital direction command and an analog direction command are supplied for the game apparatus body to selectively use the data.

The command levers of the controller may have a mechanism other than the above-described mechanism of the controller according to the third embodiment to detect continuously changing command amounts. It is possible to provide command buttons for outputting one command by one operation in place of the command levers provided on the operational surface, which is the back side of the controller body, and when the controller is held with the hands, the controller can be easily operated with the fingers other than the thumbs, which are not used, and can have more command buttons than the conventional controller.

In the above-described embodiments, the present invention is applied to the controller to be used with a game apparatus, but may be applied to controllers as an input means for controlling electronic devices other than game apparatuses.

In the present specification, "continuously" in "continuously changing", "continuous command directions", etc. include not only the so-called continuous analog amounts, but also digital amounts of digital signals converted from analog signals, which strictly are not continuous but discrete, but can be seen as continuous in terms of signal processing.

INDUSTRIAL APPLICABILITY

The present invention is suitable as a controller for supplying various commands to an electronic apparatus by operation of the controller by an operator; and more

specifically as a controller of a game apparatus, for supplying commands corresponding to game contents

Claims

5

1. A controller expansion unit which is to be inserted between a controller body including an operation key and a game apparatus, and which supplies a command signal generated by the operation key of the controller body to the game apparatus body.

10

2. A controller expansion unit according to claim 1, comprising:

15

function expansion means for expanding a function of the controller body; and
conversion means for converting the command signal from the controller body, based on a function expanded by the function expansion means, and supplying the converted command signal to the game apparatus body.

20

3. A controller expansion unit according to claim 2, wherein

25

the function expansion means includes photo signal outputting means for outputting the signal to the game apparatus body as a photo signal, and

30

the photo signal outputted by the photo signal outputting means is detected by photo signal detecting means of the game apparatus body.

35

4. A controller expansion unit according to claim 4, wherein

40

the function expansion means includes photo signal detecting means for detecting a photo signal from the outside, and

45

the conversion means combines the photo signal from the photo signal detecting means with the command signal from the controller body.

50

5. A controller expansion unit according to claim 2, wherein

55

the function expansion means includes vibration means for giving a vibration to the controller body, based on a signal from the game apparatus body or the controller body.

60

6. A controller expansion unit according to claim 2, wherein

65

the function expansion means includes an operation key for effecting a specific operation, and

the conversion means combines an operation signal generated by the specific operation key with the command signal from the controller body.

7. A controller expansion unit according to claim 2, wherein

the function expansion means includes memory means for storing information, and the memory means stores information supplied from the game apparatus body or the controller body, or information supplied to the game apparatus body or the controller body.

8. A controller expansion unit according to claim 2, wherein

the function expansion means includes display means for displaying information, and the display means displays information from the game apparatus body or the controller body.

9. A controller expansion unit according to claim 2, wherein

the function expansion means includes clock means for counting time, and time display means for displaying time, and the conversion means combines time information counted by the clock means with the command signal from the controller body.

10. A controller expansion unit according to claim 2, wherein

the function expansion means includes rotation angle detecting means for detecting a rotation angle of the controller body supported thereon, and the conversion means combines a rotation angle signal detected by the rotation angle detecting means with the command signal from the controller body.

11. A controller expansion unit according to claim 2, wherein

the function expansion means includes inclination detecting means for detecting an inclination of the controller body, and the conversion means combines an inclination signal detected by the inclination detecting means with the command signal supplied from the controller body.

12. A controller expansion unit according to claim 11,

wherein

the conversion means supplies an inclination signal given by the inclination detecting means as an alternative to a direction command signal from the controller body.

13. A controller comprising:

a controller body including an operation key; and
a controller expansion unit according to any one of claims 1 to 12.

14. A controller comprising, on an operation surface of a body of the controller, a direction key for a direction command, and a plurality of command buttons for outputting a single command,

the operation surface of the controller body having a substantially circular outer edge so that an operator can grip the controller body at any position around the outer edge of the operation surface.

15. A controller according to claim 14, wherein

a part of the outer edge of the operation surface of the controller body is shaped in relation to a specific direction of the direction key so that, when the operator grips the operation surface with his hand, he can know the specific direction of the direction key.

16. A controller according to claim 14, wherein

the controller body includes lugs to be held by the operator, and a part of a lug is shaped in relation to a specific direction of the direction key so that, when the operator grips the operation surface with his hand, he can know the specific direction of the direction key.

17. A controller comprising:

a controller body;
a direction key disposed on a first operational surface of the controller body, and commanding a direction;
a plurality of command buttons disposed on the first operational surface and outputting one command by one operation; and
a command lever disposed on a second operational surface of the controller and outputting continuously changed command amounts by one operation.

18. A controller according to claim 17, wherein

the direction key comprises:
 a direction key operating unit;
 discrete direction determining means for deter- 5
 mining a specific direction out of a plurality of
 prescribed directions, based on a state of the
 direction key operating unit; and
 continuous direction determining means for
 determining continuous command directions, 10
 based on a state of the direction key operating
 unit.

19. A controller according to claim 18, wherein

the direction key further includes change-over 15
 means for changing between the discrete
 direction determining means and the continu-
 ous direction determining means.

20. A controller according to any one of claims 17 to 19,
 wherein

the command lever is a command button which 20
 outputs one command by one operation.

21. A controller according to any one of claims 17 to 19,
 wherein

the direction key and the command buttons are 30
 disposed at positions which facilitate operation
 with the left and the right thumbs of an operator
 when he holds the controller body with the left
 and the right hands, and the command lever is
 disposed at a position which facilitates opera- 35
 tion with fingers other than the thumbs.

22. A controller according to any one of claims 17 to 21,
 wherein

the controller body includes two grips to be 40
 held by an operator; and
 the direction key and the command buttons are
 disposed at positions which facilitate operation
 with the left and the right thumbs of the opera- 45
 tor when he holds the two grips with the left and
 the right hands, and the command lever is dis-
 posed at a position which facilitates operation
 with fingers other than the thumbs.

23. A controller according to claim 22, wherein

a projection is provided on the second opera- 50
 tional surface of the controller body;
 the controller can be placed on a flat surface, 55
 supported by the projection and the two grips;
 the direction key and the command buttons are
 disposed at positions which facilitate operation

with the left and the right thumbs of an operator
 when the controller is placed on a flat surface,
 and the command lever is disposed at a posi-
 tion which facilitates operation with fingers
 other than the thumbs.

24. A game apparatus connected to the controller
 according to any one of claims 13 to 23 and execut-
 ing a game to be controlled by a command from the
 controller.

FIG. 1

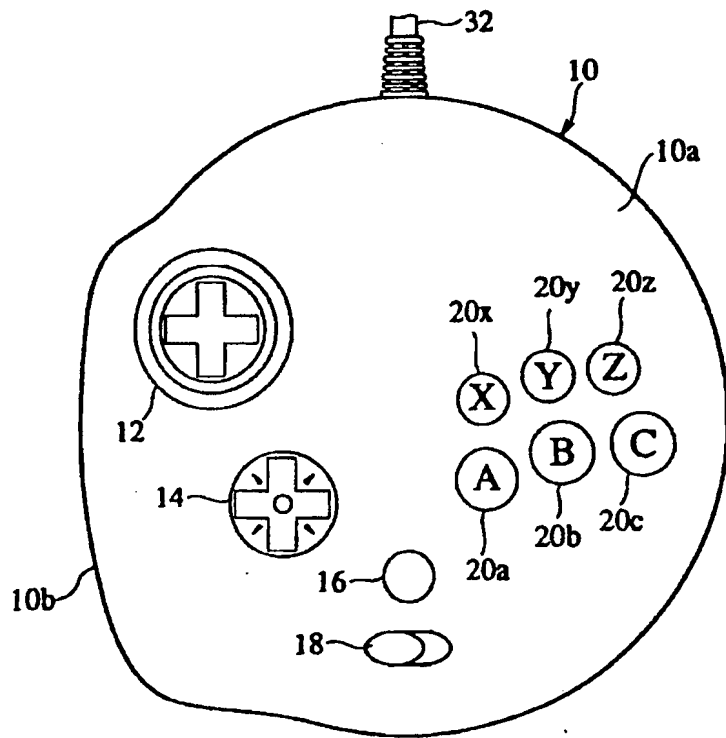

FIG. 2

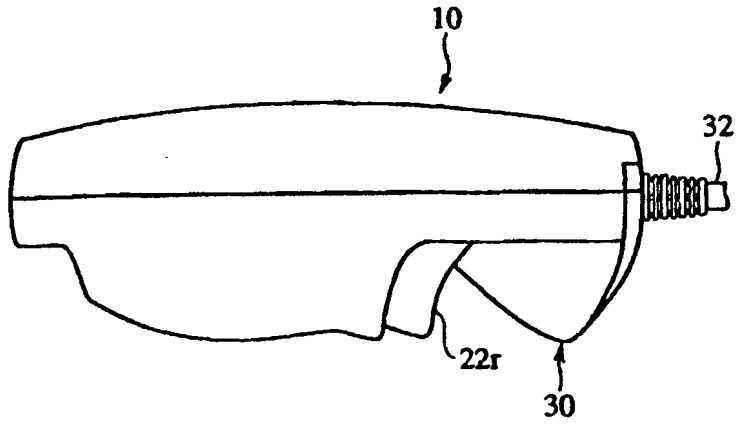

FIG. 3

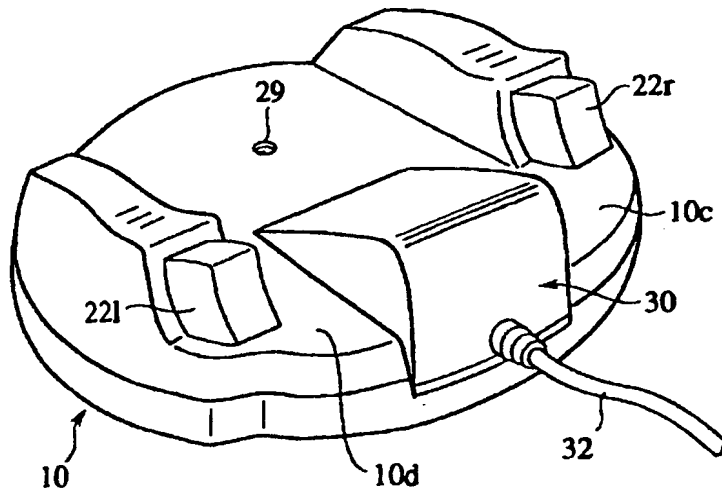

FIG. 4

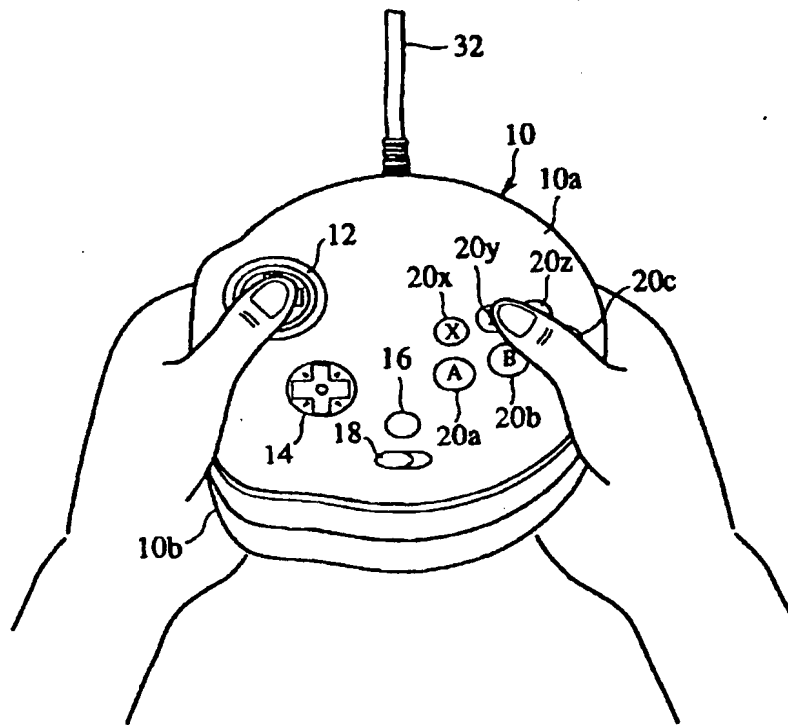

FIG. 5

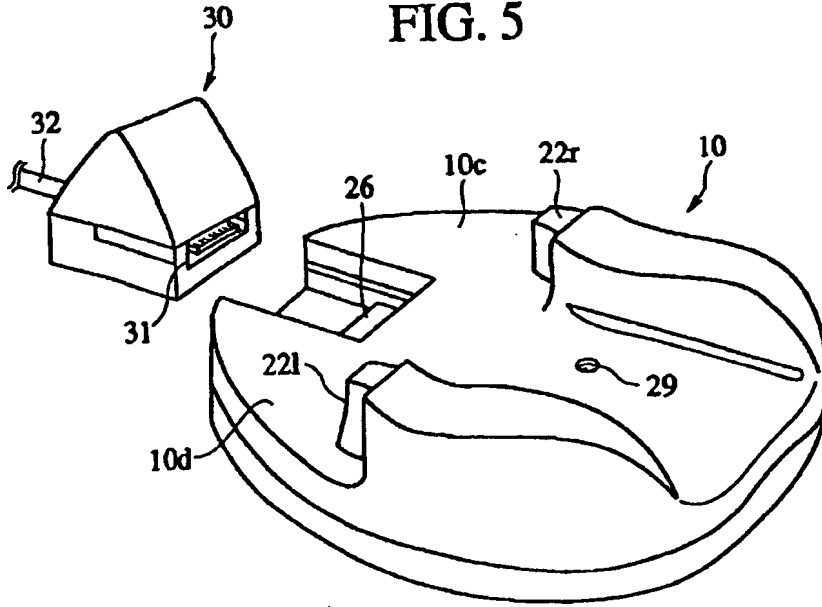

FIG. 6A

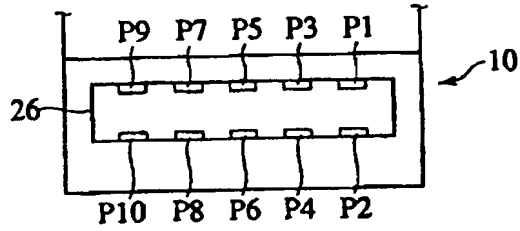

FIG. 6B

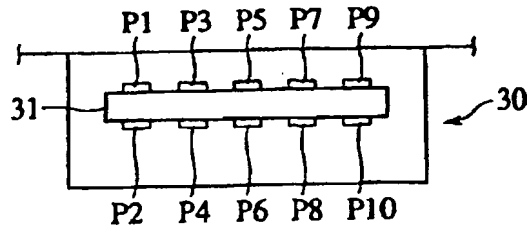
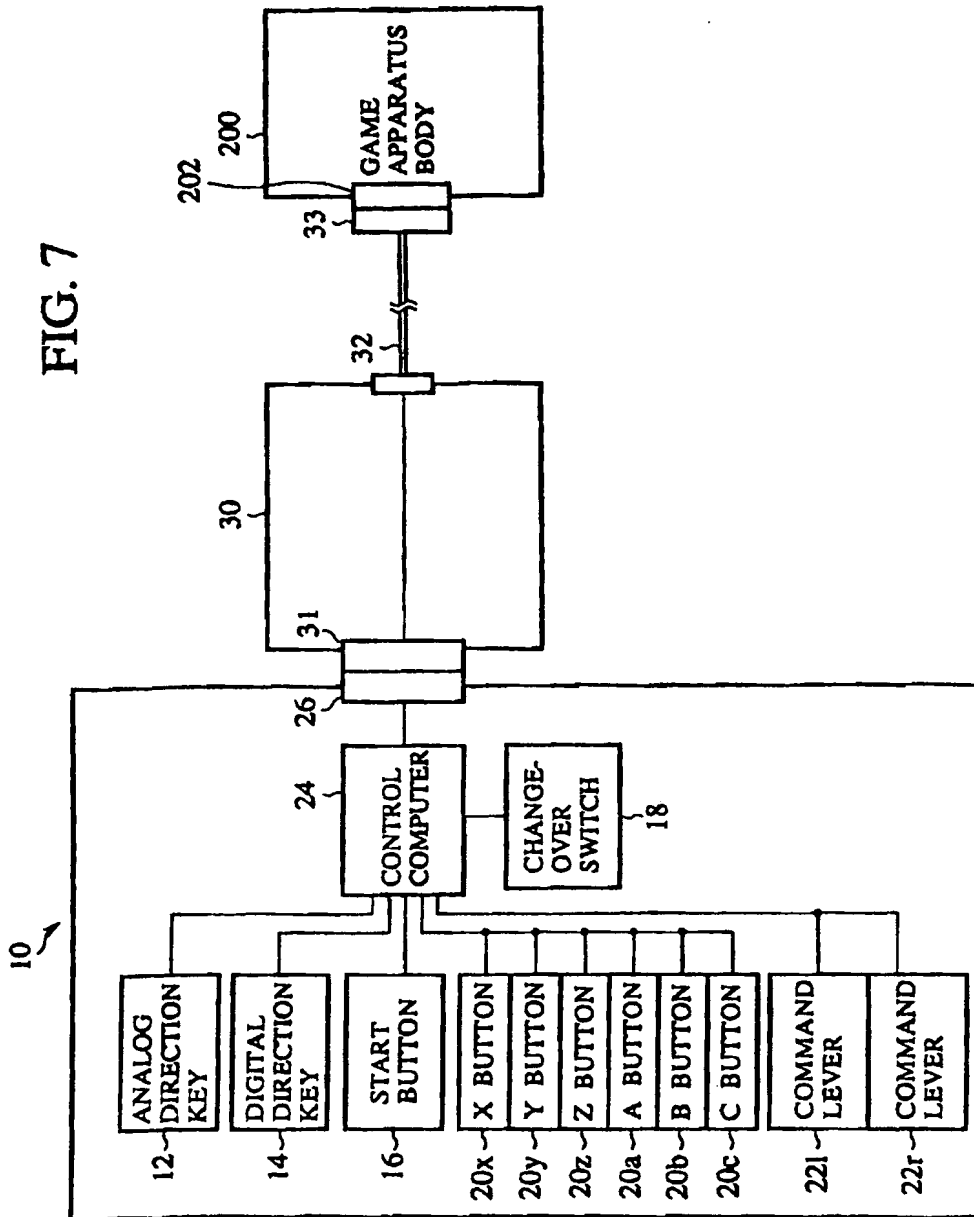

FIG. 7



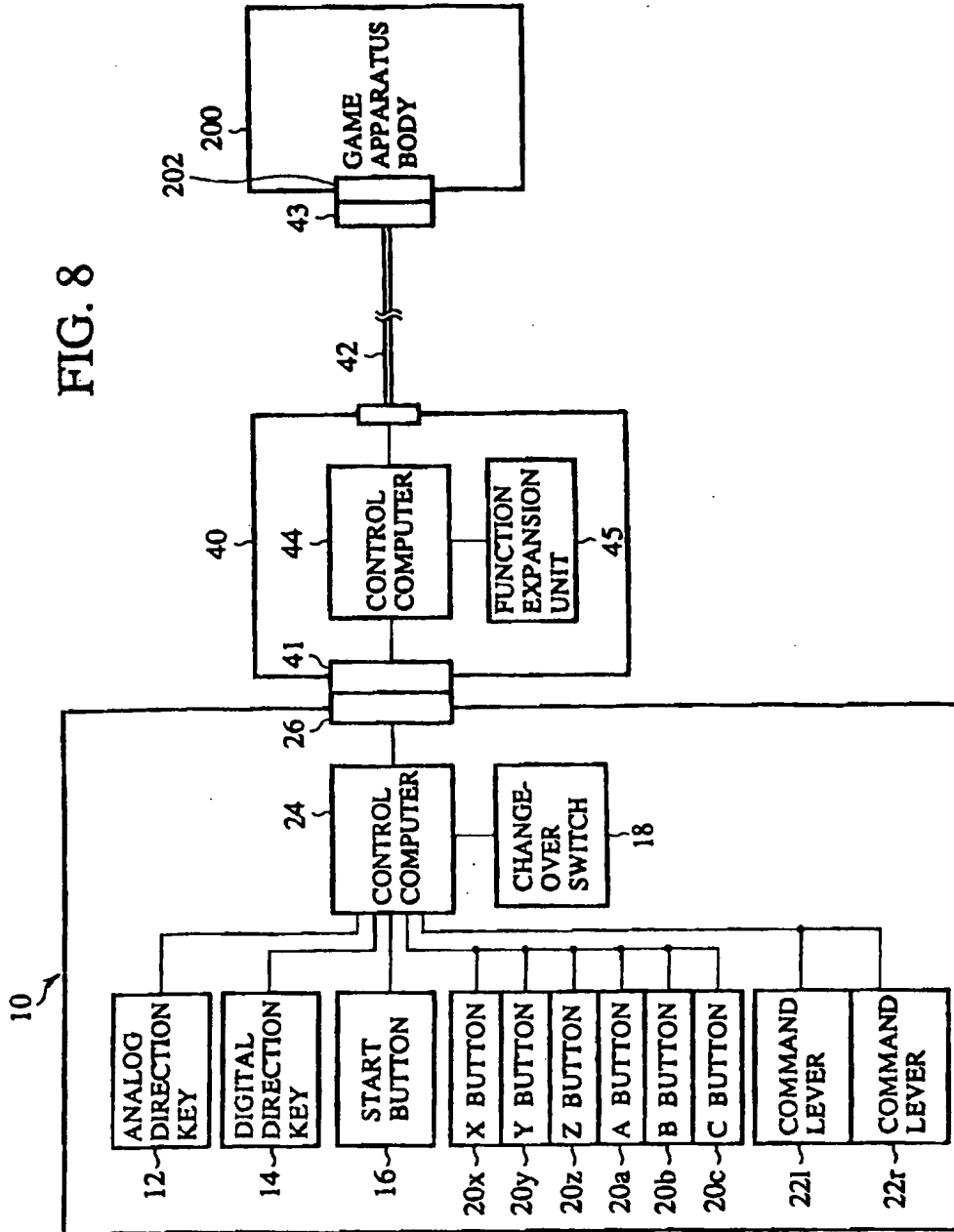

FIG. 9A

PIN ARRANGEMENT OF EXPANSION UNIT 26
FOR CONTROLLER BODY 10

SIGNAL NAME	PIN NO.	CONTENTS
TH	P4	MAINLY CONTROL LINE (SELECT) FROM EXPANSION UNIT
TR	P5	MAINLY CONTROL LINE (REQUEST) FROM EXPANSION UNIT
TL	P6	MAINLY CONTROL LINE (RESPONSE) TO EXPANSION UNIT
R	P7	MAINLY DATA LINE (3 BITS)
L	P8	MAINLY DATA LINE (2 BITS)
D	P2	MAINLY DATA LINE (1BIT)
U	P3	MAINLY DATA LINE (0 BIT)
VCC	P1	ELECTRIC POWER SOURCE (+5V)
GND	P9	GND

FIG. 9B

PIN ARRANGEMENT OF CONNECTOR 41
FOR EXPANSION UNIT 40

SIGNAL NAME	PIN NO.	CONTENTS
TH	P4	MAINLY CONTROL LINE (SELECT) TO CONTROLLER
TR	P5	MAINLY CONTROL LINE (REQUEST) TO CONTROLLER
TL	P6	MAINLY CONTROL LINE (RESPONSE) FROM CONTROLLER
R	P7	MAINLY DATA LINE (3 BITS)
L	P8	MAINLY DATA LINE (2 BITS)
D	P2	MAINLY DATA LINE (1BIT)
U	P3	MAINLY DATA LINE (0 BIT)
VCC	P1	ELECTRIC POWER SOURCE (+5V)
GND	P9	GND

FIG. 10A

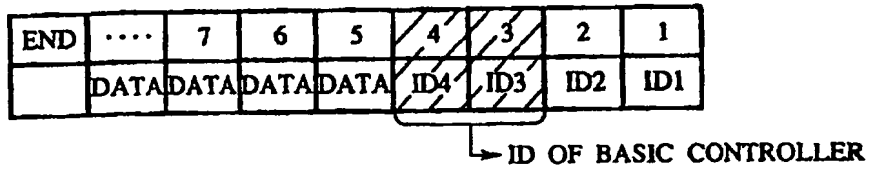

FIG. 10B

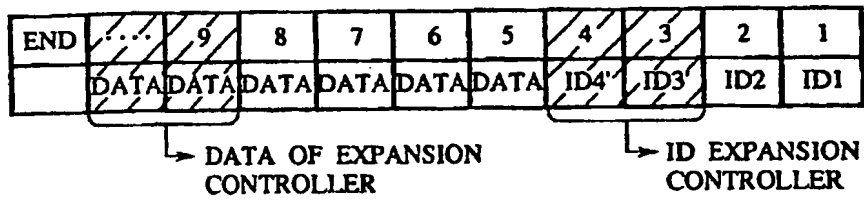

FIG. 10C

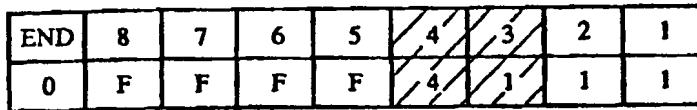

FIG. 10D

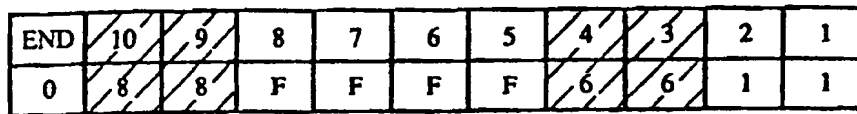

FIG. 11

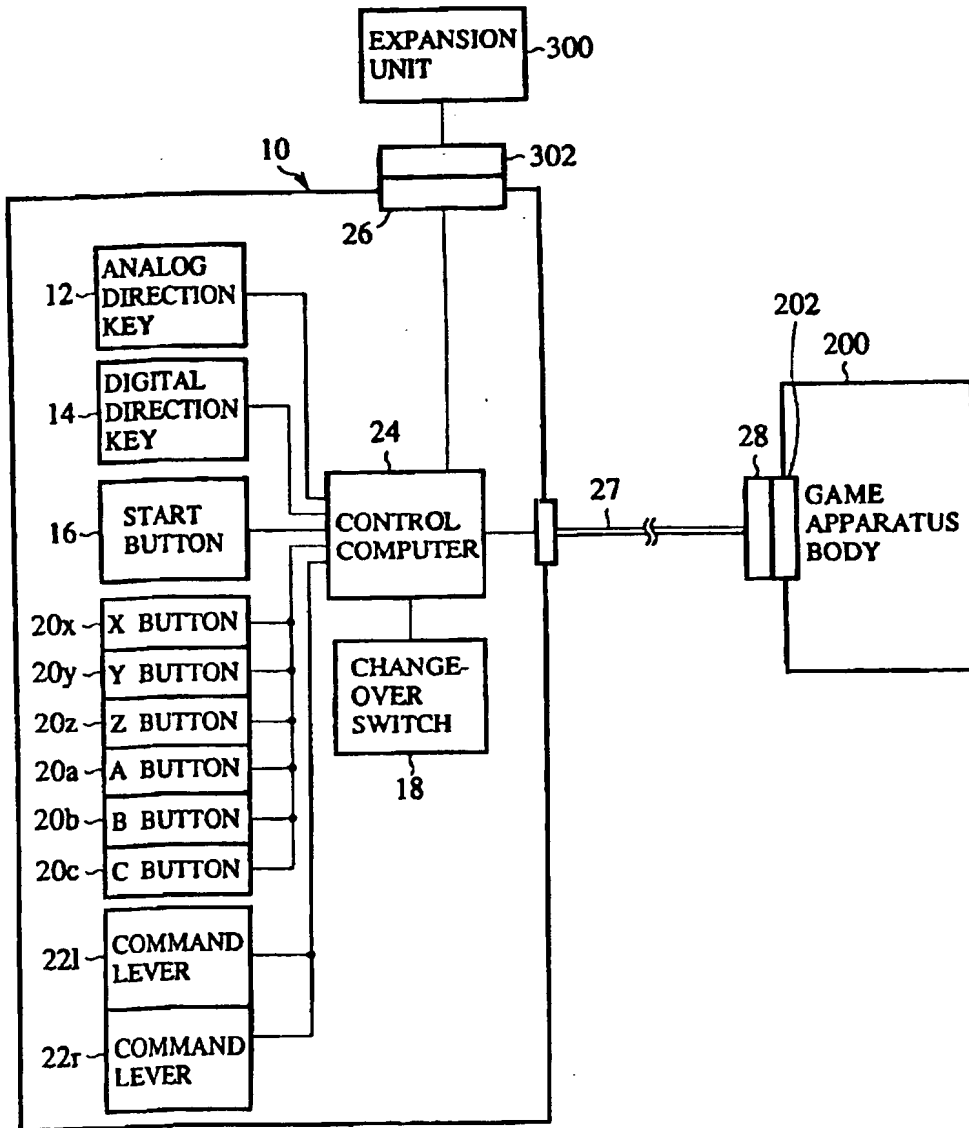

FIG. 12

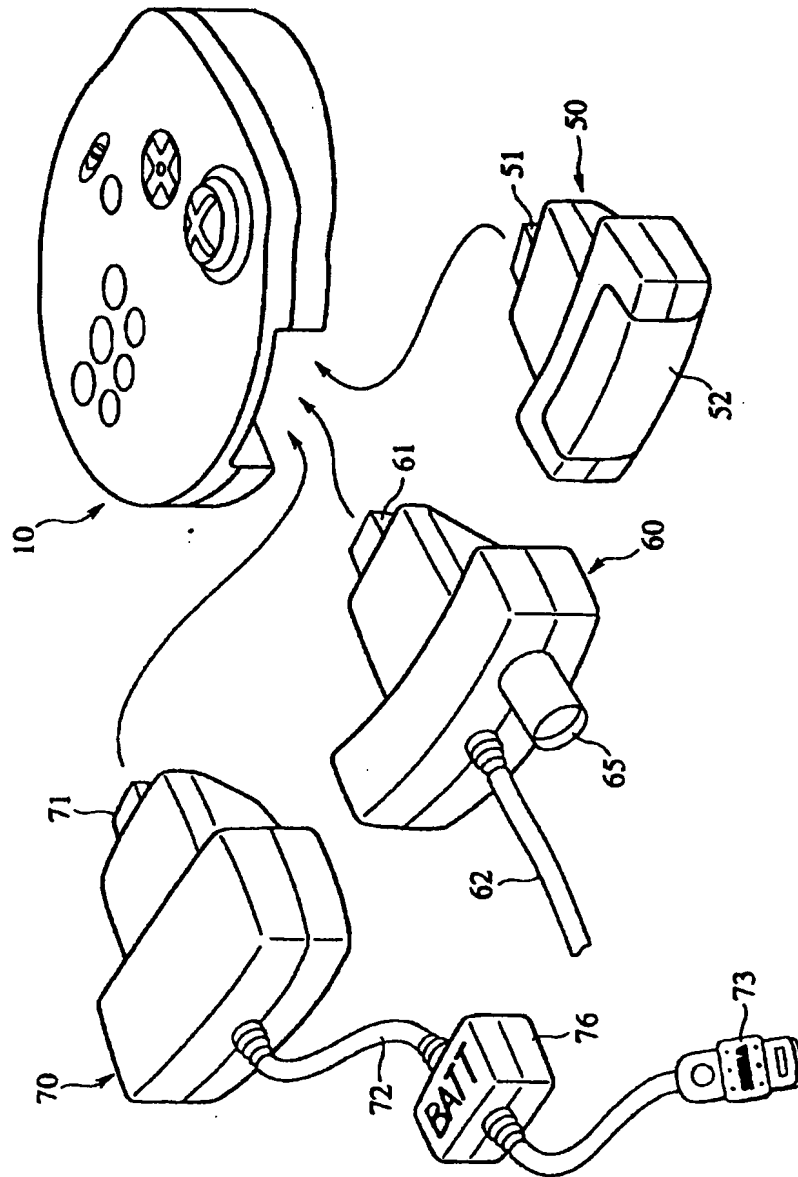

FIG. 13

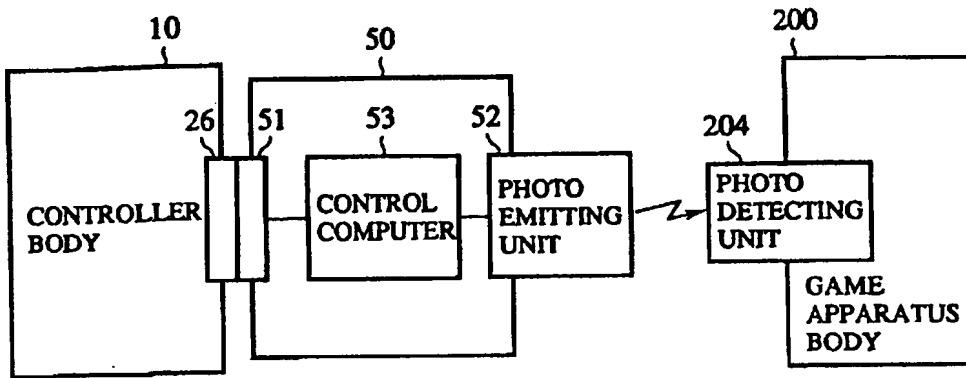

FIG. 14

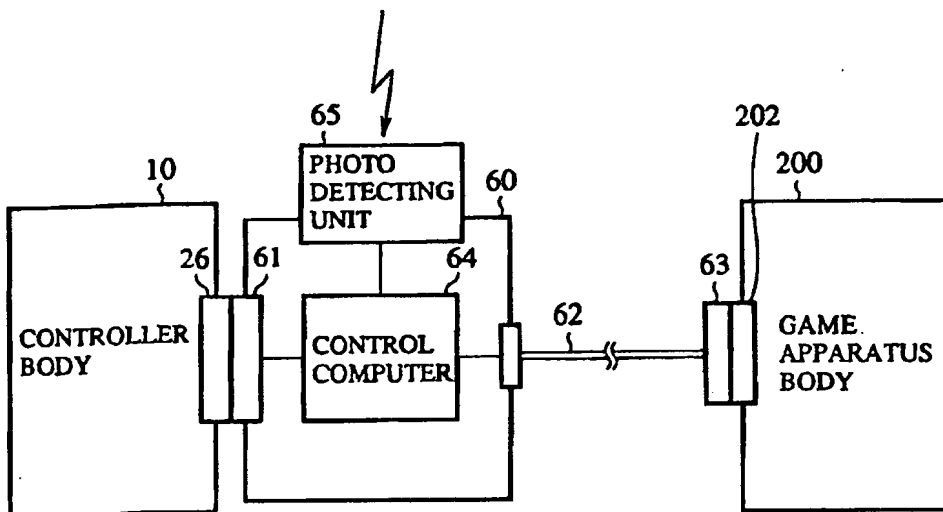

FIG. 15

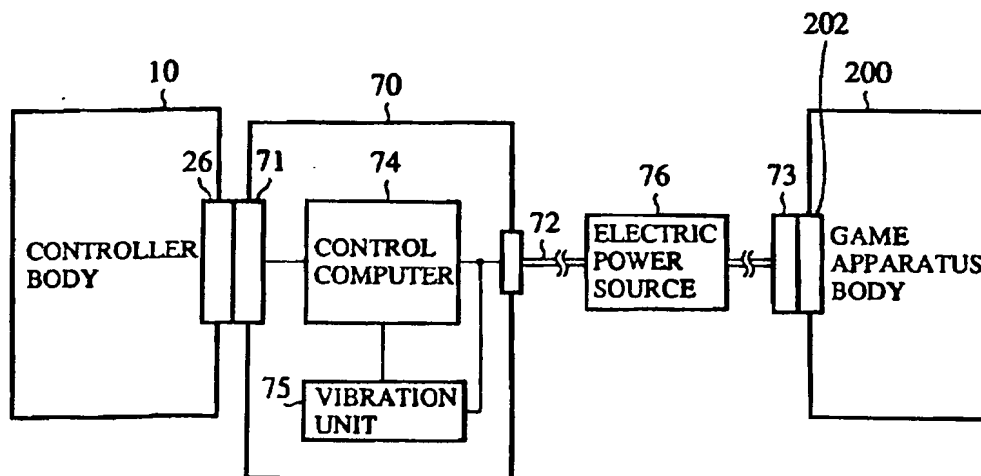

FIG. 16

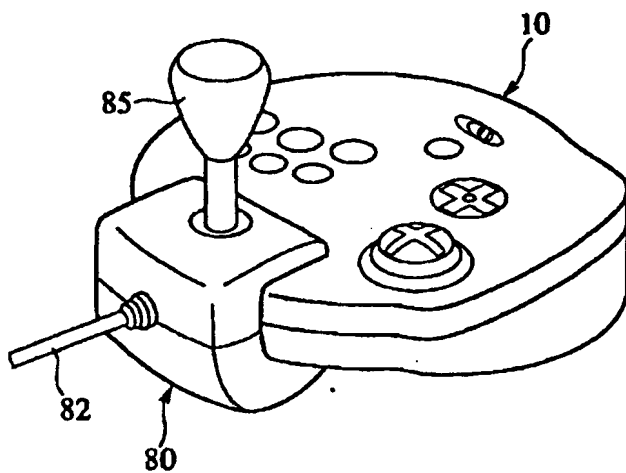

FIG. 17

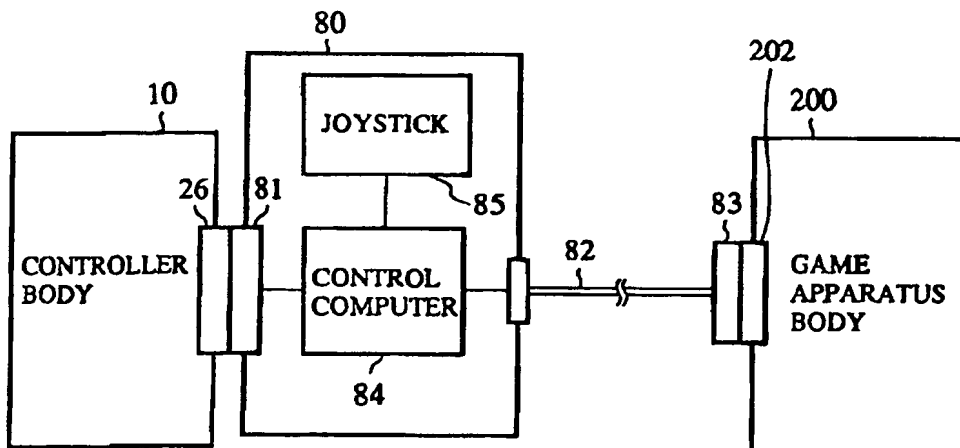

FIG. 18

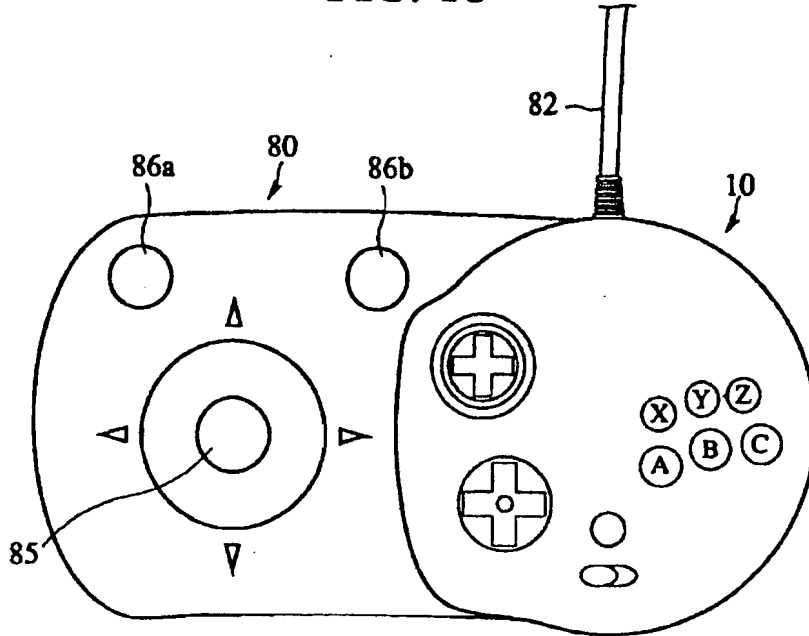

FIG. 19

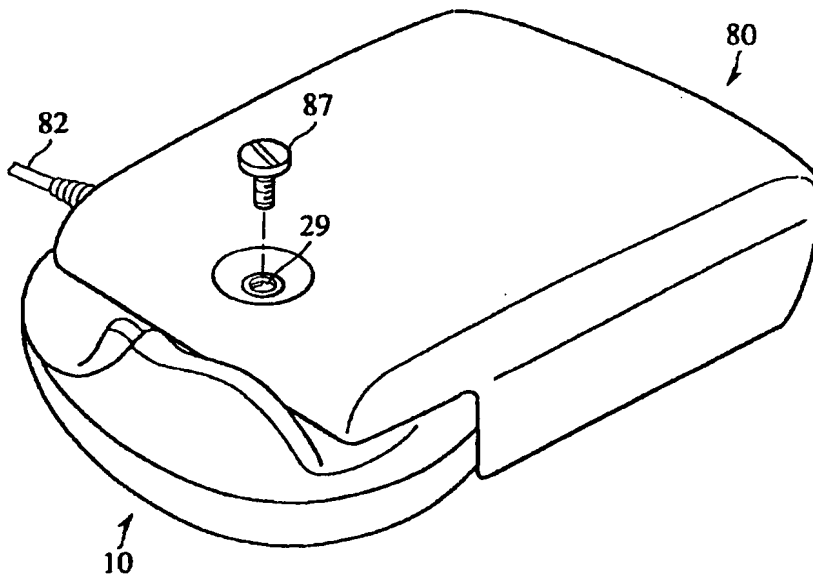

FIG. 20

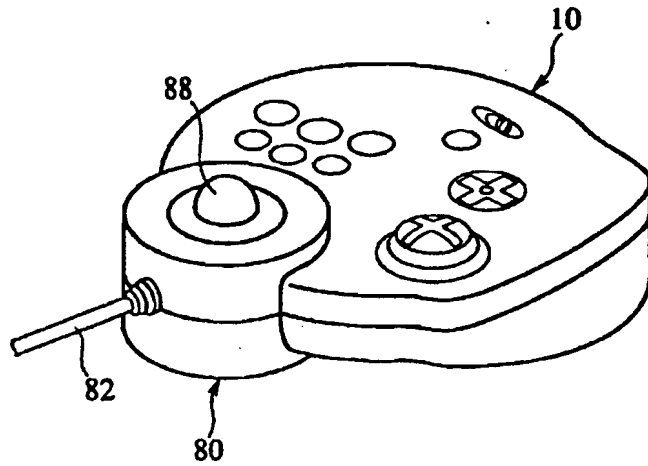

FIG. 21

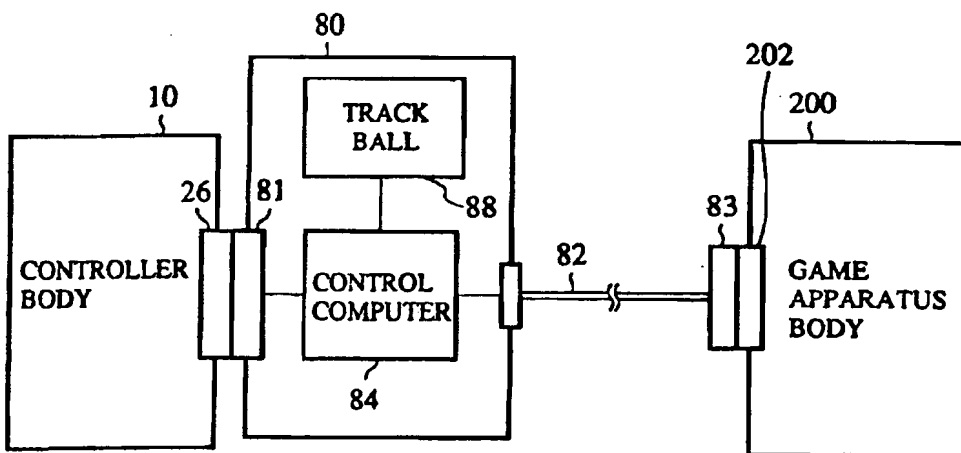

FIG. 22

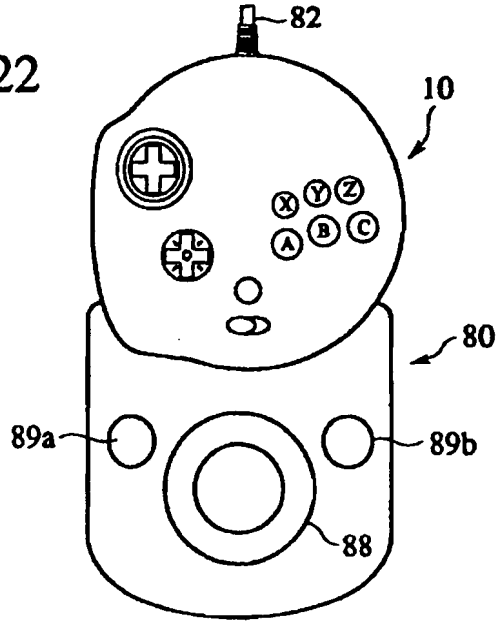

FIG. 23

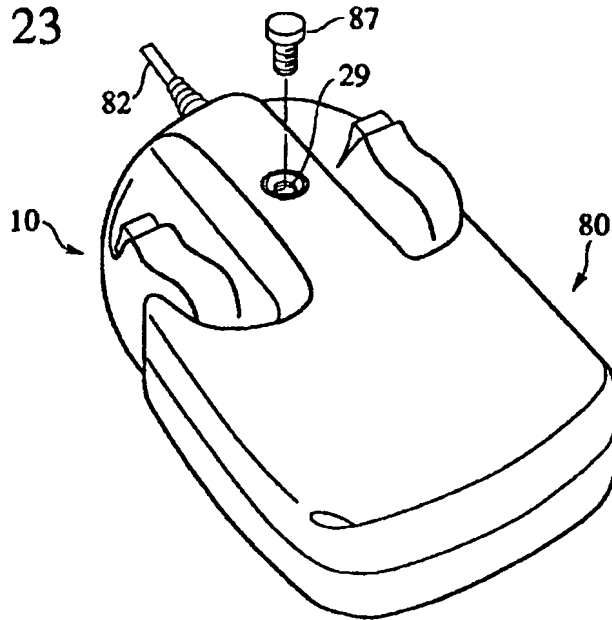

FIG. 24

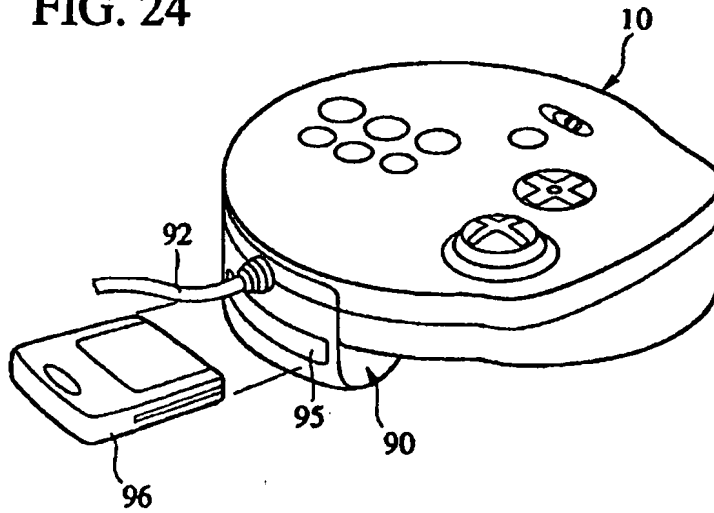

FIG. 25

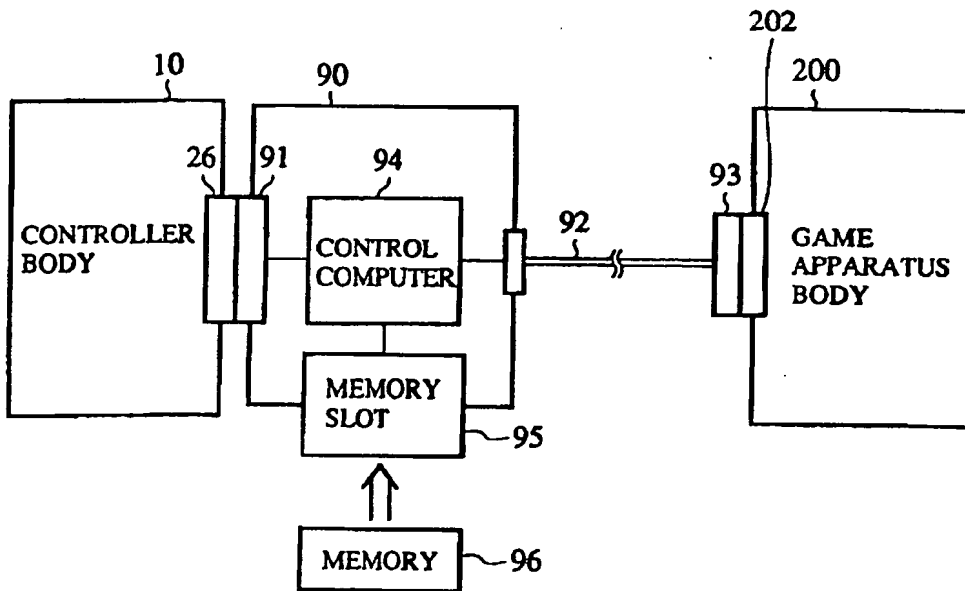

FIG. 26

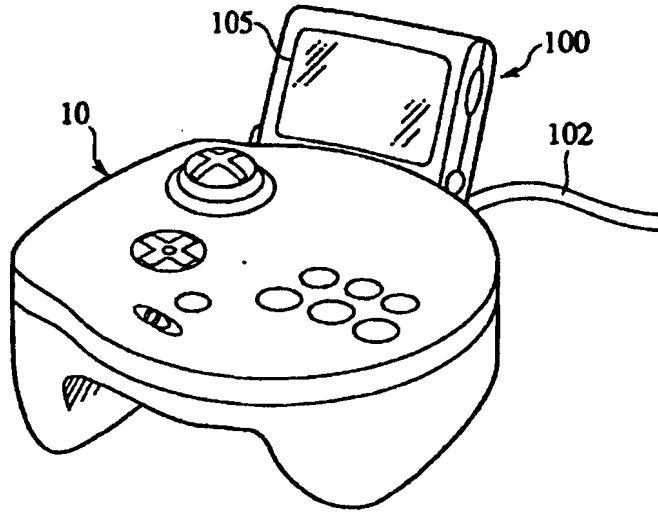

FIG. 27

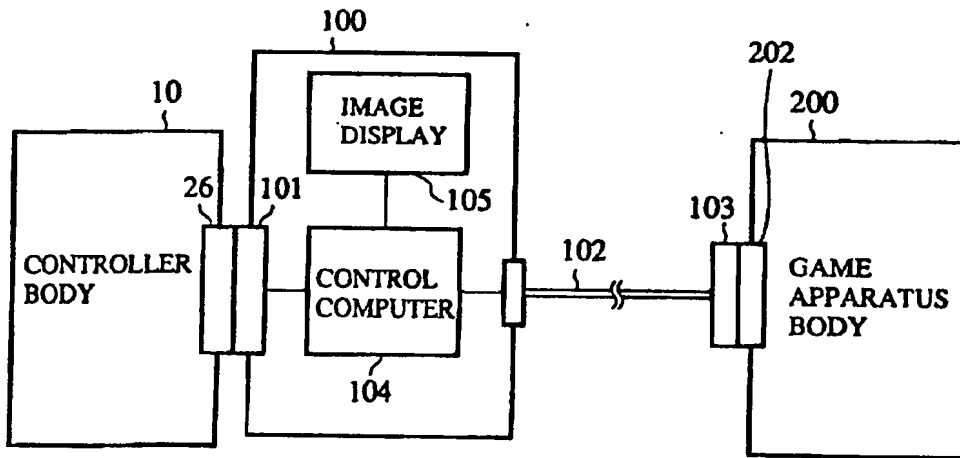

FIG. 28

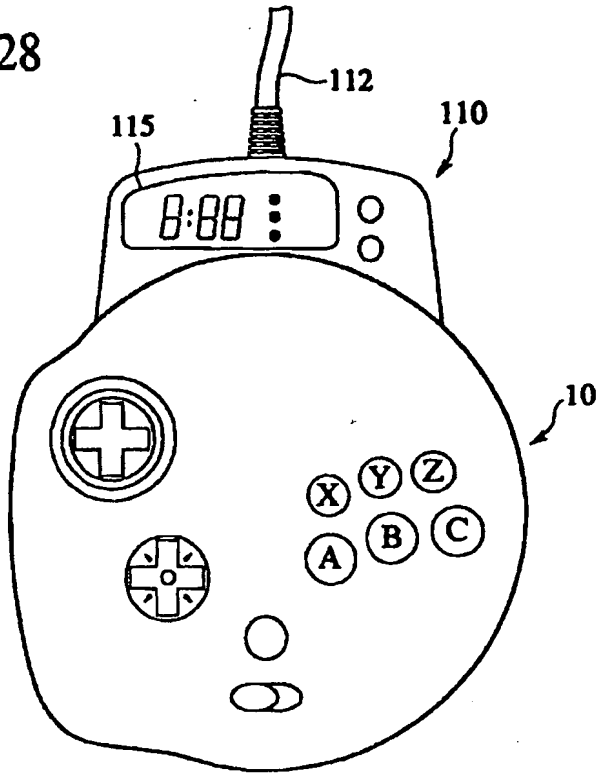

FIG. 29

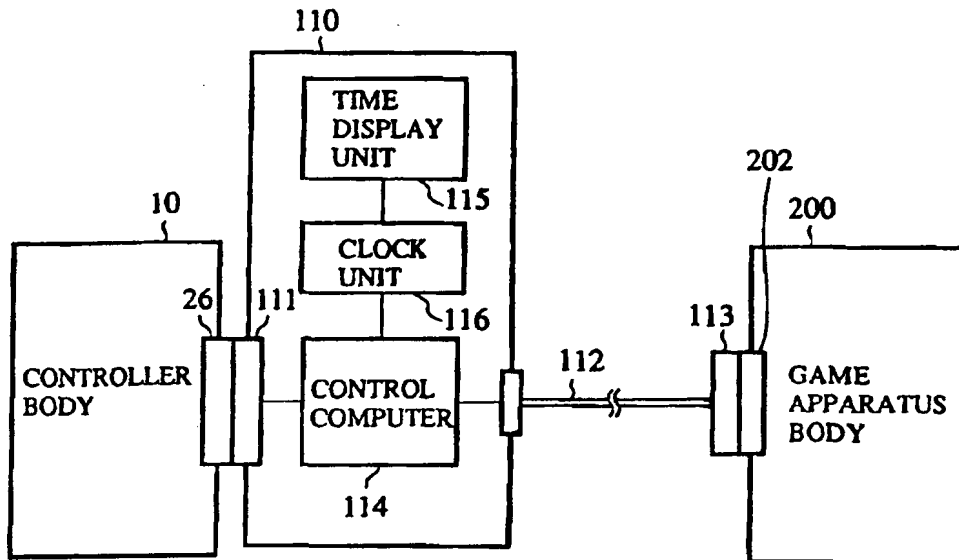

FIG. 30

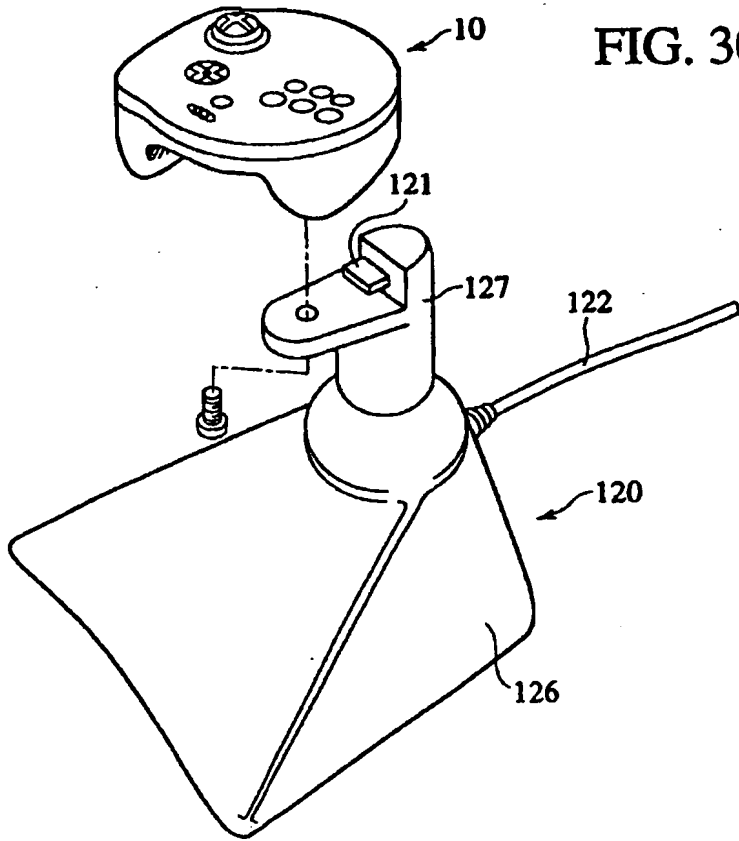

FIG. 31

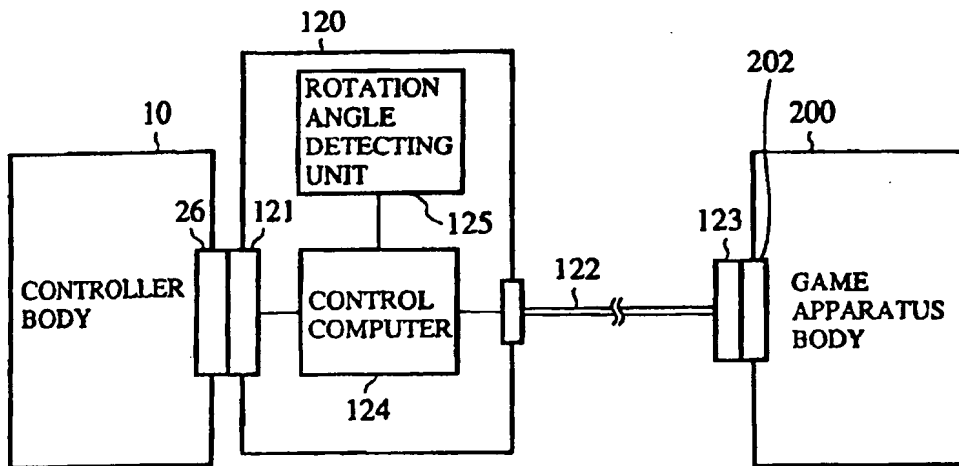

FIG. 32

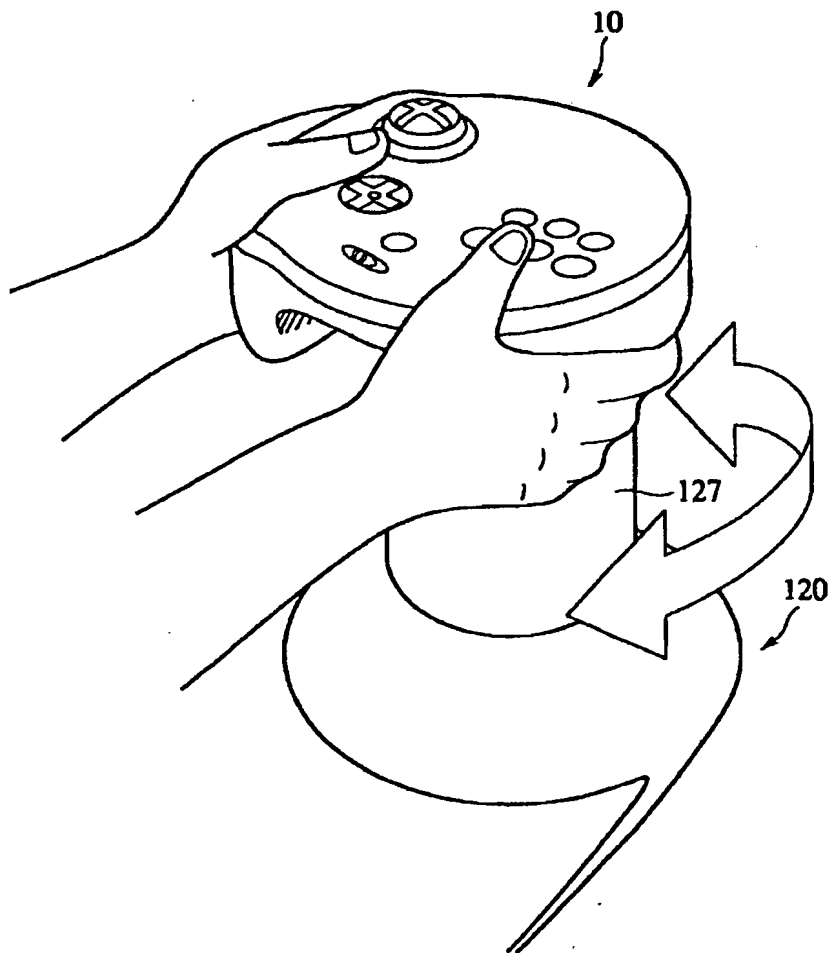

FIG. 33

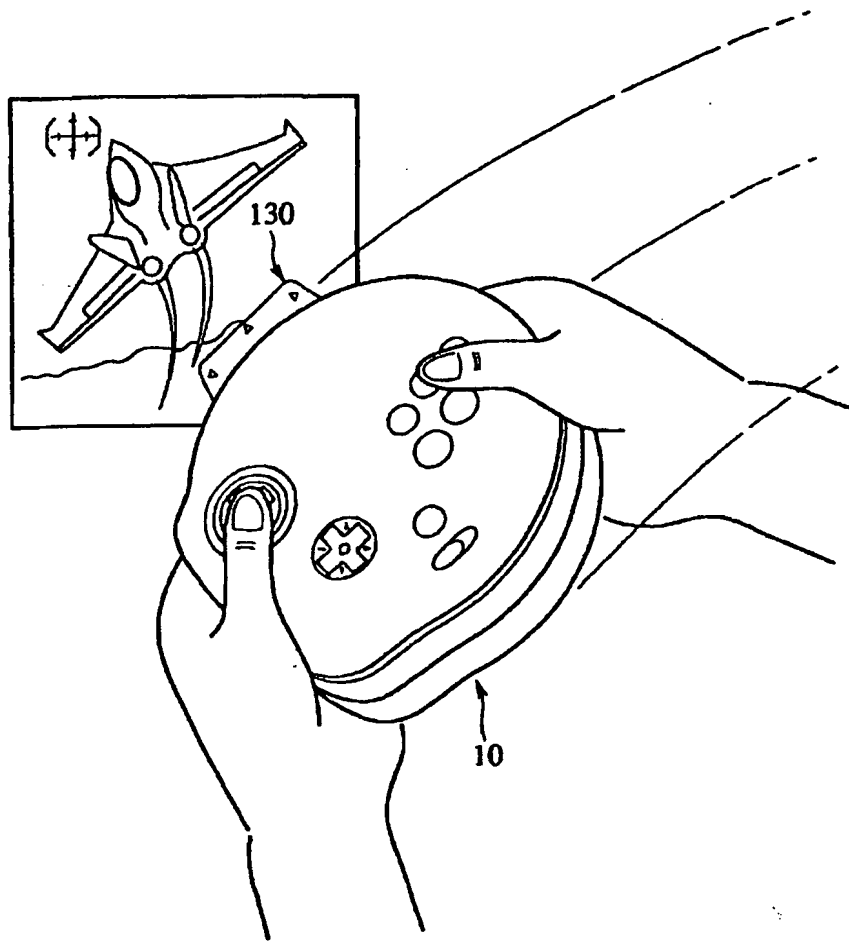

FIG. 34

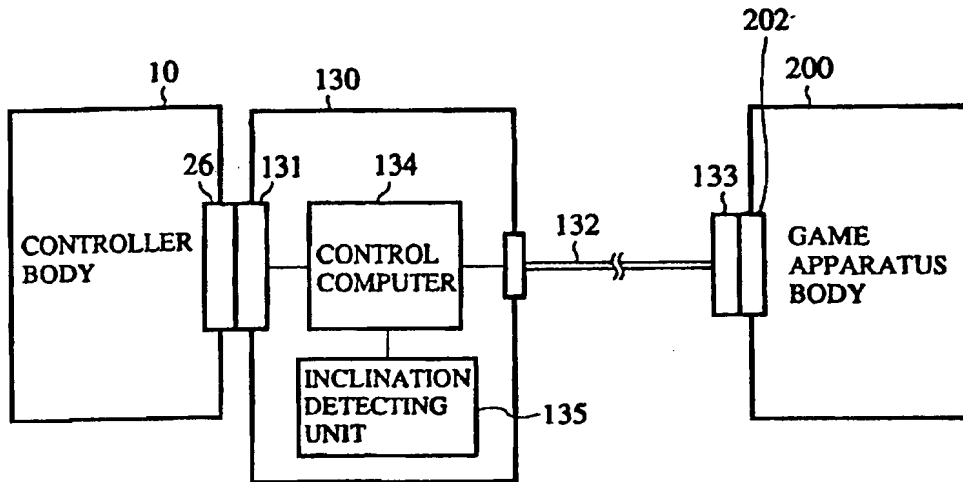

FIG. 35

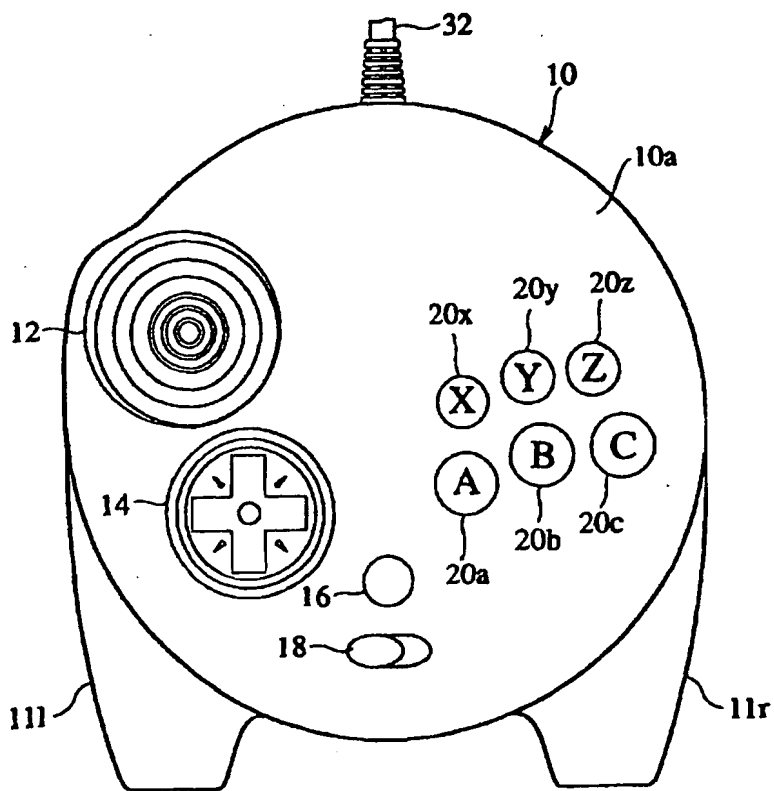

FIG. 36

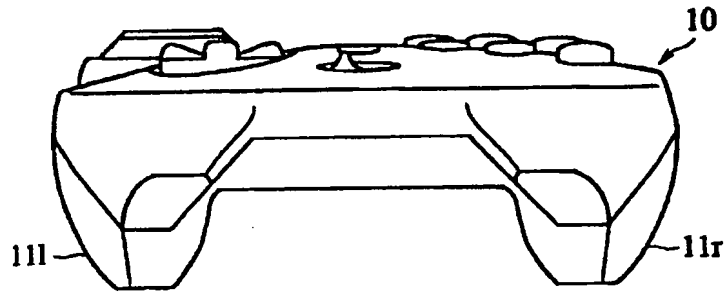

FIG. 37

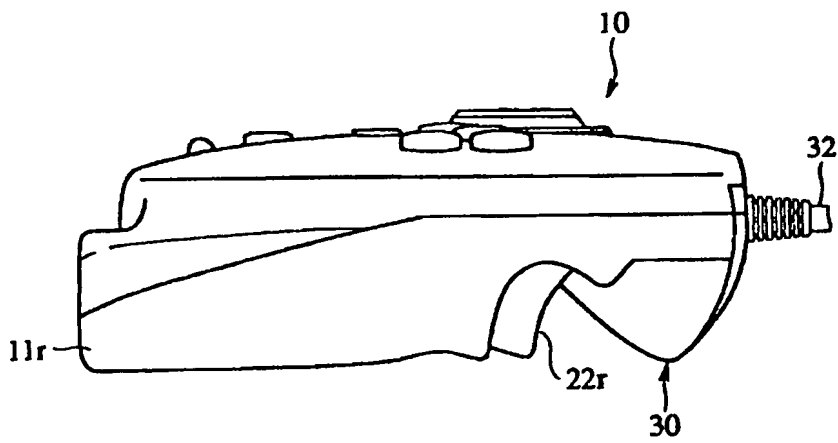
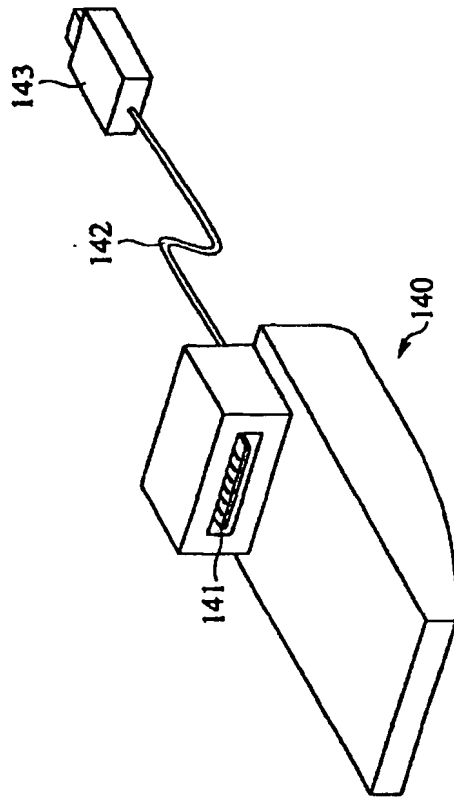

FIG. 38



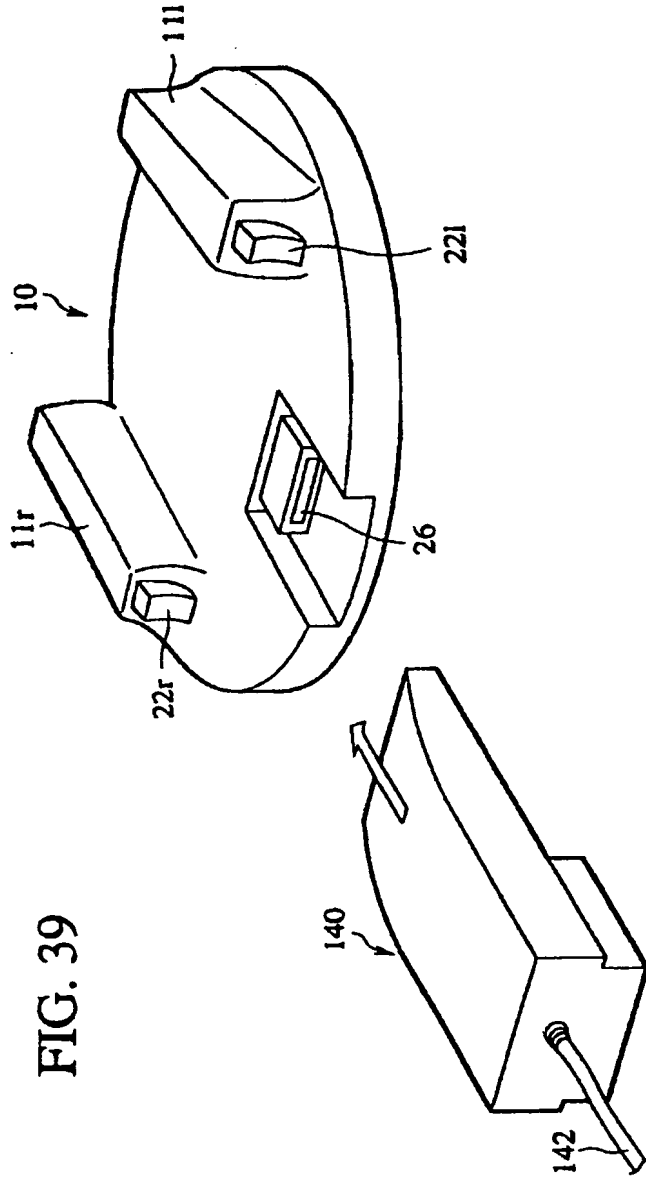

FIG. 39

FIG. 40

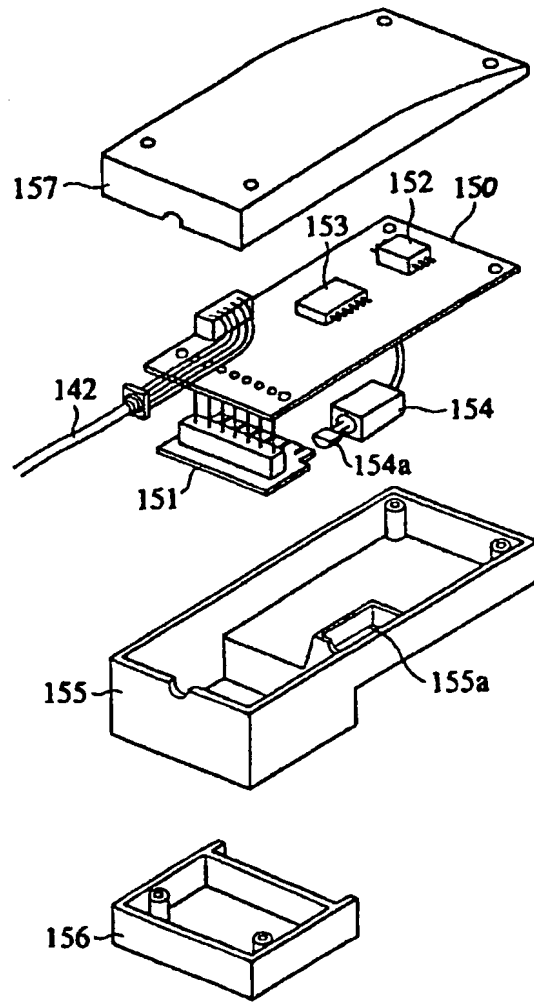

FIG. 41

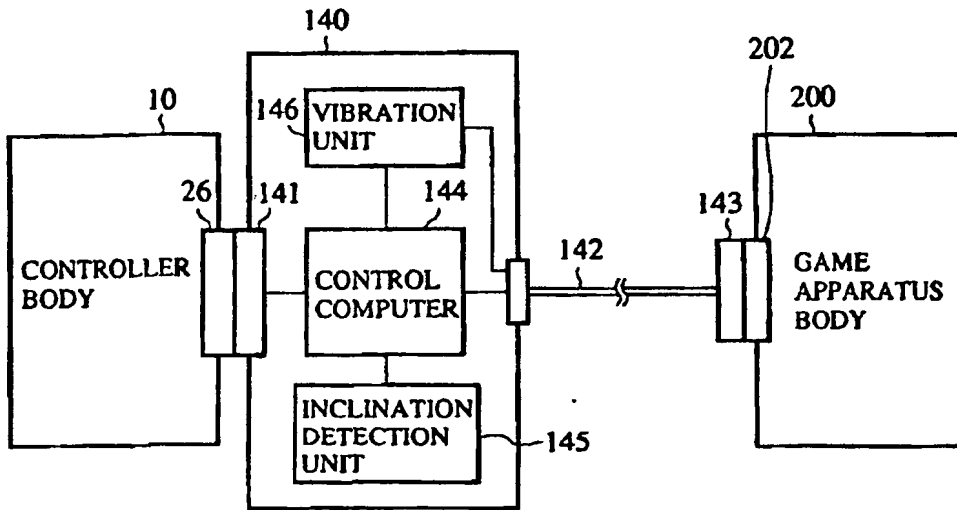

FIG. 42A

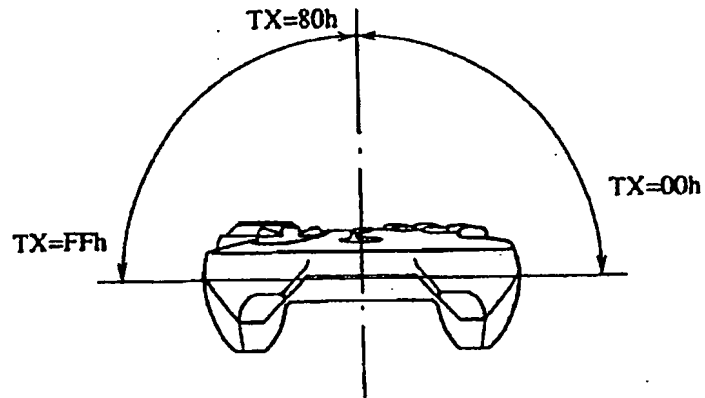

FIG. 42B

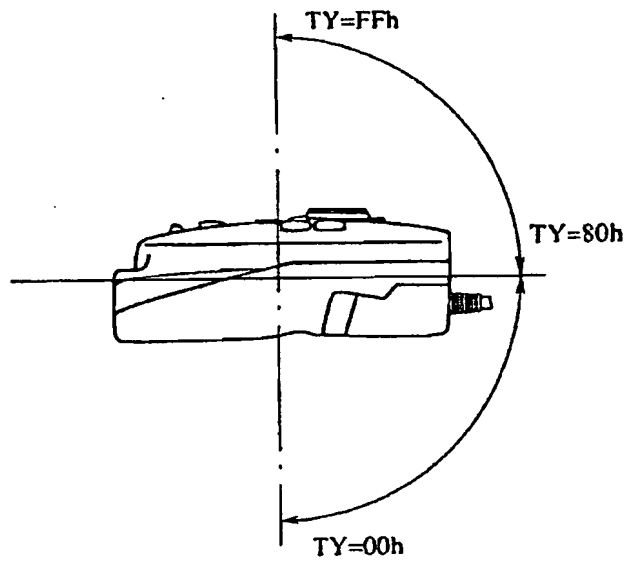

FIG. 43

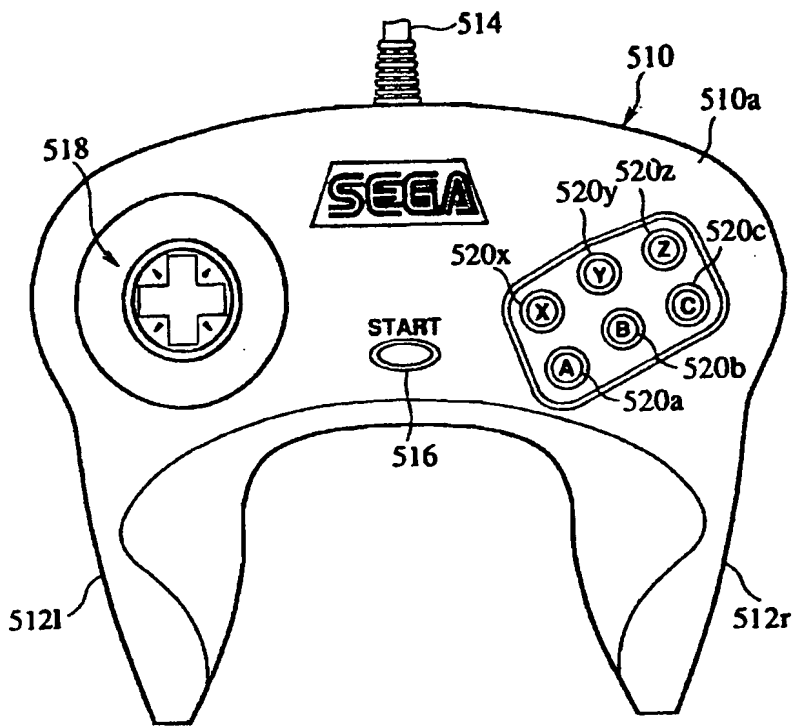

FIG. 44

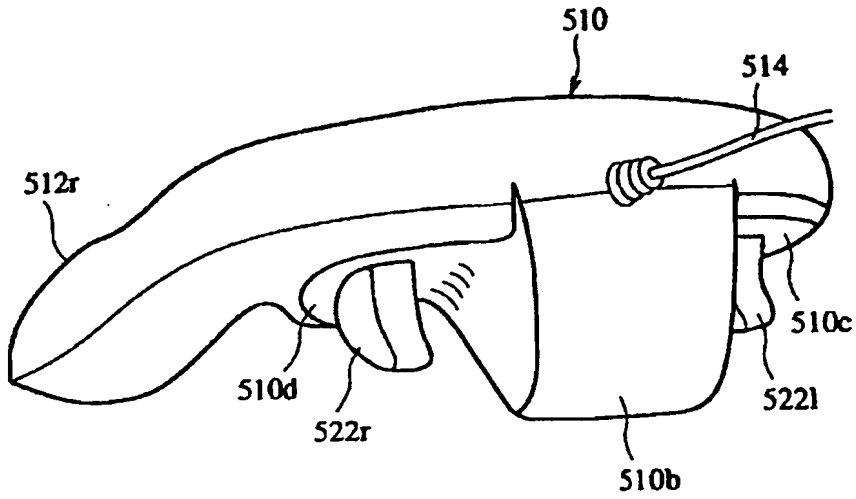

FIG. 45

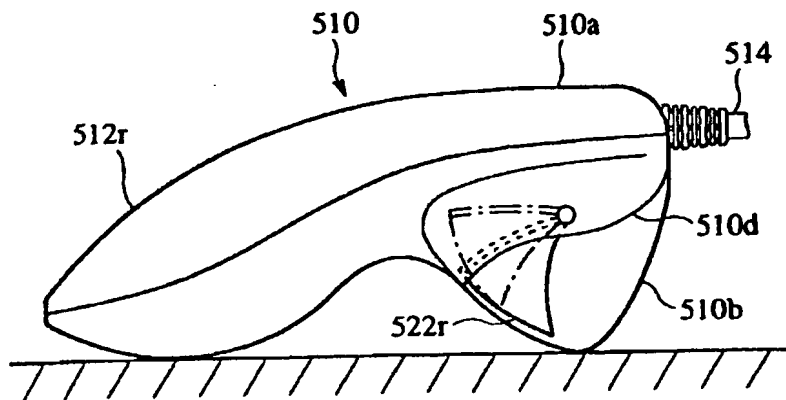

FIG. 46

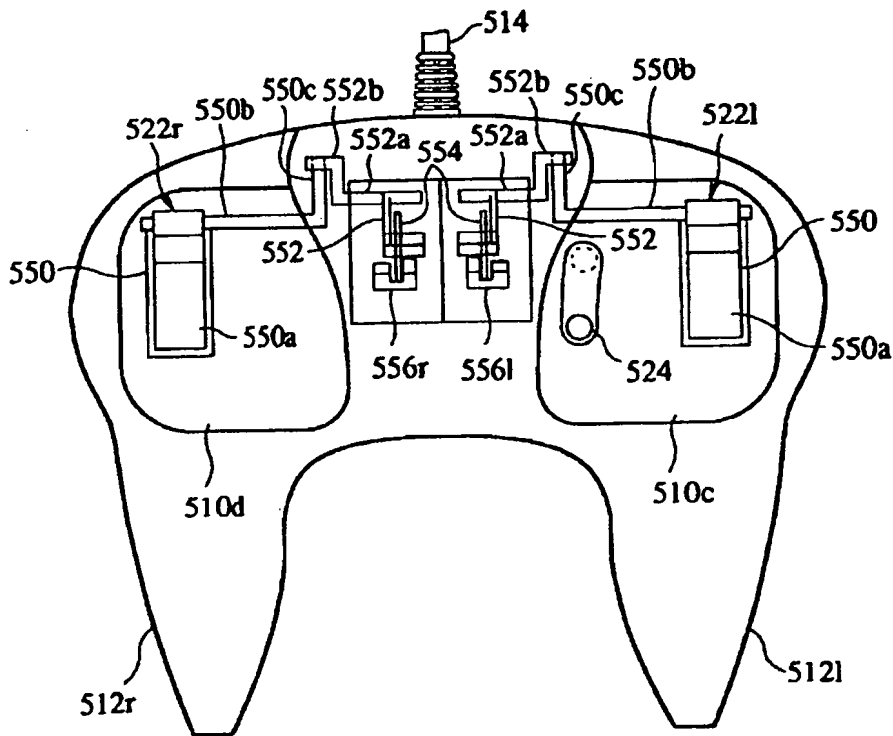

FIG. 47

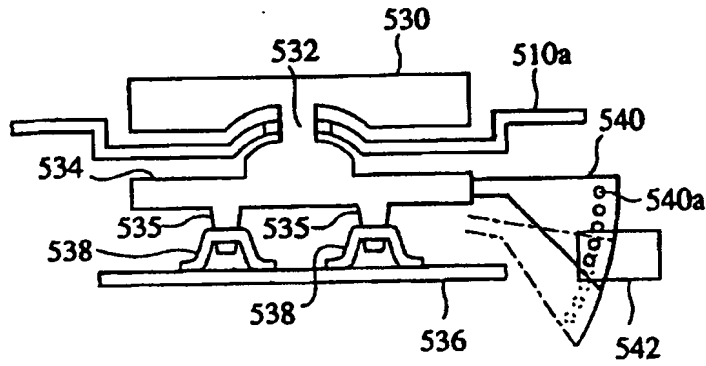

FIG. 48A

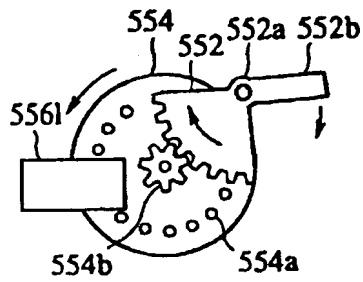

FIG. 48B

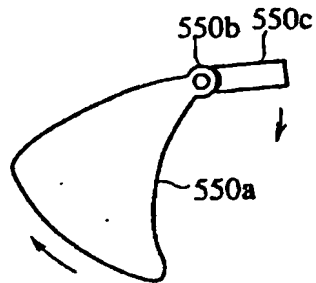

FIG. 49

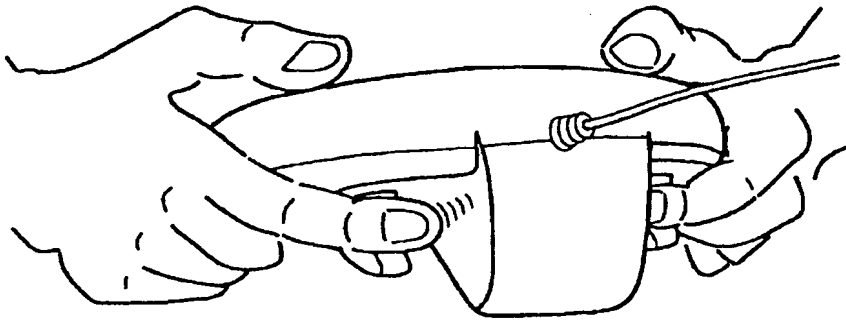
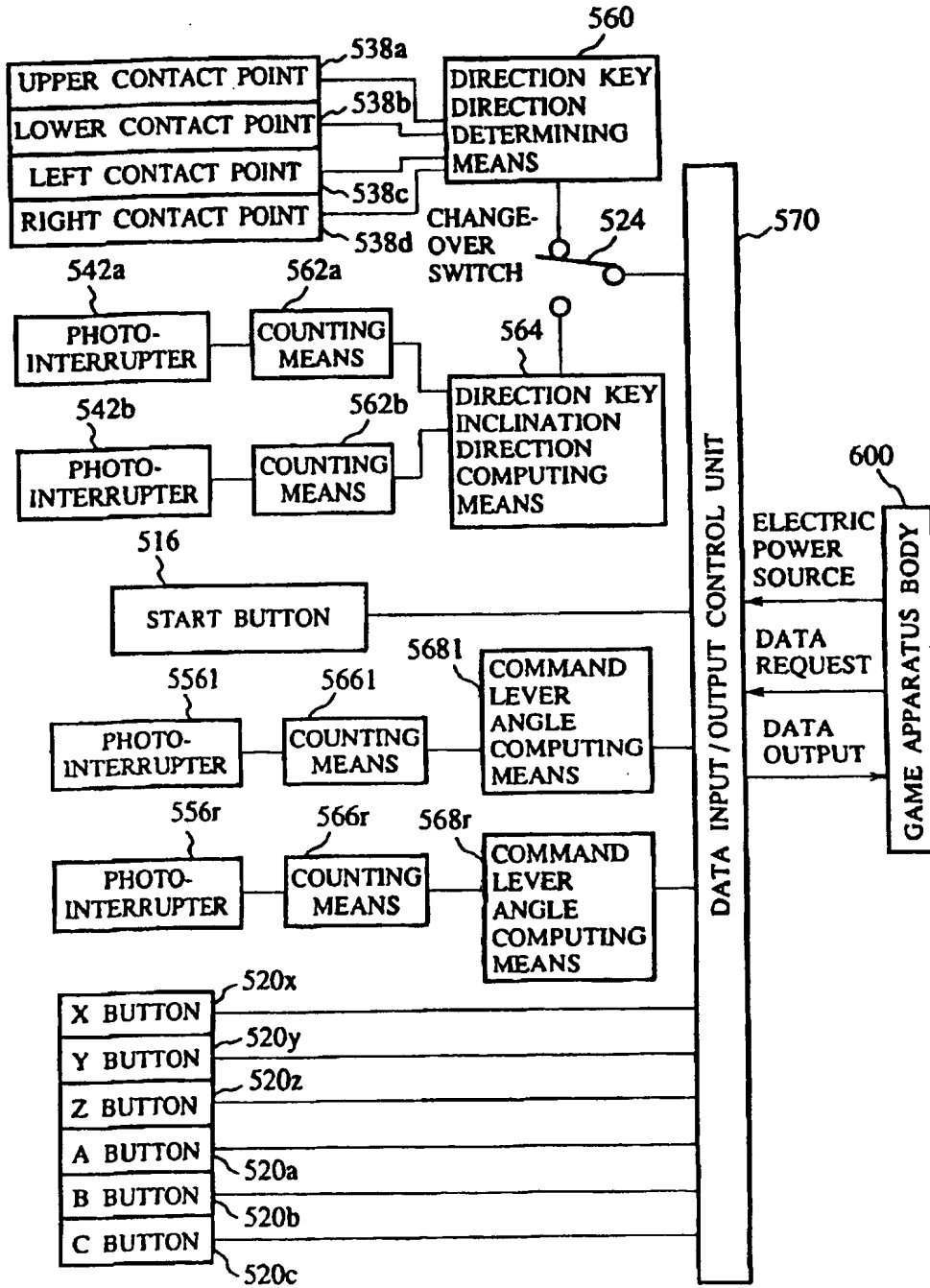

FIG. 50



INTERNATIONAL SEARCH REPORT

International application No.

PCT/JP97/00483

A. CLASSIFICATION OF SUBJECT MATTER Int. Cl ⁶ A63F9/22 According to International Patent Classification (IPC) or to both national classification and IPC		
B. FIELDS SEARCHED Minimum documentation searched (classification system followed by classification symbols) Int. Cl ⁶ A63F9/22 Documentation searched other than minimum documentation to the extent that such documents are included in the fields searched Jitsuyo Shinan Koho 1922 - 1997 Kokai Jitsuyo Shinan Koho 1971 - 1997 Toroku Jitsuyo Shinan Koho 1994 - 1997 Electronic data base consulted during the international search (name of data base and, where practicable, search terms used)		
C. DOCUMENTS CONSIDERED TO BE RELEVANT		
Category*	Citation of document, with indication, where appropriate, of the relevant passages	Relevant to claim No.
X	JP, 2-182281, A (Kyushu Hitachi Maxell K.K.), July 16, 1990 (16. 07. 90) (Family: none) Full descriptions; Figs. 1 to 4	1-3, 24 4 - 13
Y	Full descriptions; Figs. 1 to 4 Microfilm of the specification and drawings annexed to the written application of Japanese Utility Model Application No. 105901/1985 (Laid-open No. 14527/1987) (Aruyume K.K.), January 28, 1987 (28. 01. 87) (Family: none)	1-3, 6, 24 4-5, 7-13
X	Full descriptions; Figs. 1 to 3	
Y	Full descriptions; Figs. 1 to 3	
Y	JP, 2-182282, A (Kyushu Hitachi Maxell K.K.), July 16, 1990 (16. 07. 90), Full descriptions; Figs. 1 to 9 (Family: none)	4
Y	Microfilm of the specification and drawings annexed to the written application of Japanese Utility Model Application No. 83533/1986 (Laid-open No. 194389/1987) (Yoshitaka Mizutani).	5
<input checked="" type="checkbox"/> Further documents are listed in the continuation of Box C. <input type="checkbox"/> See patent family annex.		
* Special categories of cited documents: "A" document defining the general state of the art which is not considered to be of particular relevance "E" earlier document but published on or after the international filing date "L" documents which may throw doubts on priority claim(s) or which is cited to establish the publication date of another citation or other special reason (as specified) "O" document referring to an oral disclosure, use, exhibition or other means "T" document published prior to the international filing date but later than the priority date claimed "T" later document published after the international filing date or priority date and not in conflict with the application but cited to understand the principle or theory underlying the invention "X" document of particular relevance; the claimed invention cannot be considered novel or cannot be considered to involve an inventive step when the document is taken alone "Y" document of particular relevance; the claimed invention cannot be considered to involve an inventive step when the document is combined with one or more other such documents, such combination being obvious to a person skilled in the art "A" document member of the same patent family		
Date of the actual completion of the international search May 15, 1997 (15. 05. 97)		Date of mailing of the international search report May 27, 1997 (27. 05. 97)
Name and mailing address of the ISA/ Japanese Patent Office Facsimile No.		Authorized officer Telephone No.

INTERNATIONAL SEARCH REPORT

International application No.

PCT/JP97/00483

C (Continuation). DOCUMENTS CONSIDERED TO BE RELEVANT

Category*	Citation of document, with indication, where appropriate, of the relevant passages	Relevant to claim No.
	December 10, 1987 (10. 12. 87), Full descriptions; Figs. 1, 2 (Family: none)	
Y	CD-ROM of the specification and drawings annexed to the written application of Japanese Utility Model Application No. 12291/1992 (Laid-open No. 74589/1993) (Sekisui Chemical Co., Ltd.), October 12, 1993 (12. 10. 93), Full descriptions; Figs. 1 to 3 (Family: none)	7, 13
Y	JP, 4-174694, A (Sega Enterprises, Ltd.), June 22, 1992 (22. 06. 92) (Family: none) Full descriptions; Figs. 1, 2	8
A	Full descriptions; Figs. 1, 2	9
Y	JP, 8-47581, A (Namco Ltd.), February 20, 1996 (20. 02. 96), Full descriptions; Figs. 1 to 5 (Family: none)	10, 17
Y	Microfilm of the specification and drawings annexed to the written application of Japanese Utility Model Application No. 219/1989 (Laid-open No. 91595/1990) (Mitsubishi Electric Corp.), July 20, 1990 (20. 07. 90), Full descriptions; Figs. 1, 2 (Family: none)	11 - 12
Y	JP, 6-190144, A (Sega Enterprises, Ltd.), July 12, 1994 (12. 07. 94), Full descriptions; Figs. 1 to 7 (Family: none)	11 - 12
X	CD-ROM of the specification and drawings annexed to the written application of Japanese Utility Model Application No. 21179/1993 (Laid-open No. 73841/1994) (Sega Enterprises, Ltd.), October 18, 1994 (18. 10. 94) (Family: none) Full descriptions; Figs. 1, 2	14
Y	Full descriptions; Figs. 1, 2	15 - 16
X	CD-ROM of the specification and drawings annexed to the written application of Japanese Utility Model Application No. 21180/1993 (Laid-open No. 73842/1994) (Sega Enterprises, Ltd.), October 18, 1994 (18. 10. 94) (Family: none) Full descriptions; Figs. 1, 2	14
Y	Full descriptions; Figs. 1, 2	15 - 16
Y	JP, 8-45392, A (Nintendo Co., Ltd.), February 16, 1996 (16. 02. 96) (Family: none) Full descriptions; Figs. 1 to 10	17, 20-24
A	Full descriptions; Figs. 1 to 10	18 - 19
Y	JP, 8-24439, A (Sony Corp.), January 30, 1996 (30. 01. 96) (Family: none) Full descriptions; Figs. 1 to 17	17, 20-24
A	Full descriptions; Figs. 1 to 17	18 - 19

Form PCT/ISA/210 (continuation of second sheet) (July 1992)

Exhibit 12 to the Request for Inter Partes Re-examination of

In re Patent No: 6,347,997

Issued: February 19, 2002

Applicant: Brad A. Armstrong

Title: Analog Controls Housed with Electronic Displays